



GC 系列触摸屏（OIP）

使用说明书

前 言

感谢您购买我们的操作面板（OIP）。

在使用操作面板之前请阅读本手册，以便你能全面了解它的功能及其使用方法。

如果你需要更为详细的信息，请与当地销售员或直接与本公司联系！

注意事项：

- 请将本指导手册放在必要时可以拿到的地方。
- 本手册的内容和操作面板的规格参数可能有时会有所变动，恕不提前通知！
- 我们致力于使本手册的内容尽可能正确无误，但如确有疑点、错误或遗漏，请与我们的服务人员联系！
- Koyo 对使用本手册所产生的伤害（包括任何间接伤害）概不负责！
- 未经许可，不得转载或拷贝本手册的全部或部分內容！
- 光洋电子对本手册的全部内容保留最终解释权！

担保事项：

- 如果按照本手册的指导使用本产品，并且故障发生在质保期内，而且光洋公司承认有这种故障，那么光洋将提供免费维修或替换。
- 光洋公司对由于本产品故障所导致的任何损失或伤害不承担任何责任！

光洋电子（无锡）有限公司

地址：江苏省无锡市滨湖区建筑西路 599 号 1 栋 21 层

电话：0510—85167888 传真：0510—85161393

主页：<http://www.koyoele.com.cn/>

Koyo Electronics (WuXi) Co., LTD

Add: 21st Floor, Building 1, No.599, Jianzhuxi Road, Binhu District, Wuxi, Jiangsu, P.R.China

Tel: 0510—85167888 Fax: 0510—85161393

Homepage: <http://www.koyoele.com.cn/>

目 录

1. 安全注意事项	1
2. 包含部件	1
3. 各部件的名称和功能	2
4. 一般规格	4
5. 显示器规格	5
6. 显示功能规格	5
7. 触摸面板规格	6
8. 功能/性能规格	6
9. 编程环境	7
10. 软件规格	7
11. 安装步骤	8
11-1 安装	8
11-2 电源	11
11-3 接地	12
11-4 其它连接方式	12
12. 通信协议规格	12
13. 接口性能	15
13-1 RS232(CH1,CH2)	15
13-2 RS485(CH3)	16
13-3 打印口	18
13-4 RAS/Reset	19
13-5 使用 5V 电源（可选）时请注意	19
14. 操作准备	20
14-1 系统语言设定	20
14-2 画面下载	20
14-3 系统设置	21
14-4 操作前	25
15. 电池	26
15-1 电池类型	26
15-2 如何更换电池	26
16. 背光灯（GC-55EM2-1 无）	27
17. 维护	27
18. 定期检查	27

1. 安全注意事项:

为了安全使用本 OIP(操作面板), 请按以下所列安全注意事项操作。如果不按安全手册操作, 光洋公司对一切损失或伤害不承担任何责任。

警告:

- 设计系统时要充分考虑到怎样预防人身事故和设备损坏的发生。系统要有外部保护和安全电路, 以便即使操作面板发生故障或程序发生错误时也能保证系统的安全。
- 不要在操作面板的触摸屏上作与安全、人员或重大伤害有关的按钮(如急停安全开关等。)设计时应考虑系统能够应付操作面板的错误和故障。
- 确保接地保护端 D 安全接地, 否则会有电击的危险!
- 如果操作面板发生故障, 要立即关掉电源且将其放在一旁, 不要乱动!
- 如果有对 PLC 等外部输出设备的直接输出, 不管梯形图电路是否互锁, 直接输出将被直接驱动。该输出可以驱动诸如马达之类的负载, 因此请避免使用直接输出, 因为那样太危险了!

注意:

- 请在规定的条件下使用和存储本产品(要考虑振动、撞击、温度、湿度、等等)
- 禁止将本产品暴露在易燃易爆性气体环境和蒸汽环境下。
- 在打开电源以前请确定电源电压与产品额定电压相匹配。使用不正确的电源将损坏本产品。
- OIP 的保护接地端和信号地在内部已经被连在一块。所以, 当将 OIP 嵌入其它机器或控制装置, 要对 OIP 进行焊接工作时, 焊接电流很可能会损坏操作面板(OIP)。
- 请不要拆卸或改动操作面板(OIP), 因为这样可能导致故障发生和其它一些问题。
- 操作面板的触摸屏是用玻璃做的, 因此用硬的物体敲击或按压, 都有可能造成玻璃破碎。
- 不要用机械笔、螺丝刀、或尖的器具点击 OIP, 因为这样会损伤面板从而引发故障。
- 液晶显示器的背景使用的是冷阴极管。在最后销毁处理时, 请按当地政府部门规定的处理条例执行。
- 为了预防电击或灼伤, 在更换液晶背景时, 请先关闭电源并让其内部温度降至室温。而且, 确保高压电已完全释放。

2. 包含部件

在硬纸盒里应包含以下部件, 开盒时请仔细检查!

名称	GC-56LC2-1 (彩色)		GC-55EM2-1(高辉度 EL)		GC-53LC3-1 (彩色)		GC-53LM3-1 (单色)	
	数量	型号	数量	型号	数量	型号	数量	型号
OIP 本体	1	GC-56LC2-1	1	GC-55EM2-1	1	GC-53LC3-1	1	GC-53LM3-1
安装支架	6	GC-S1BK-1	6	GC-S1BK-1	4	GC-S3BK-2	4	GC-S3BK-2
衬垫	1	GC-S6PC-1	1	GC-S5PC-2	1	GC-S3PC-2	1	GC-S3PC-2
指导手册	1	ES-M0247	1	ES-M0247	1	ES-M0231	1	ES-M0231

3. 各部件的名称、功能及尺寸

GC-56LC2-1(彩色)

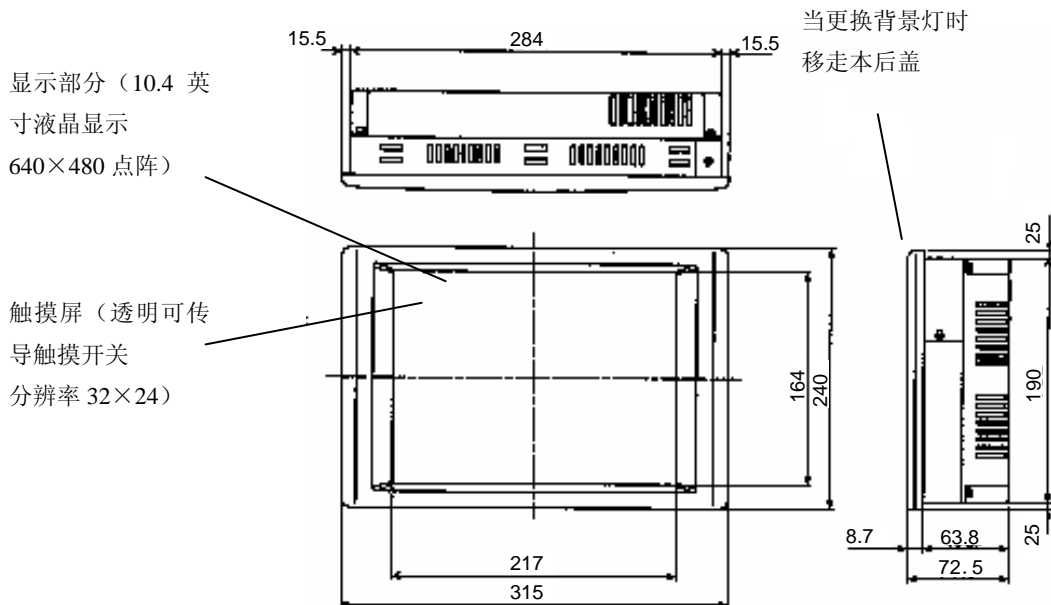

GC-55EM2-1(高辉度 EL)

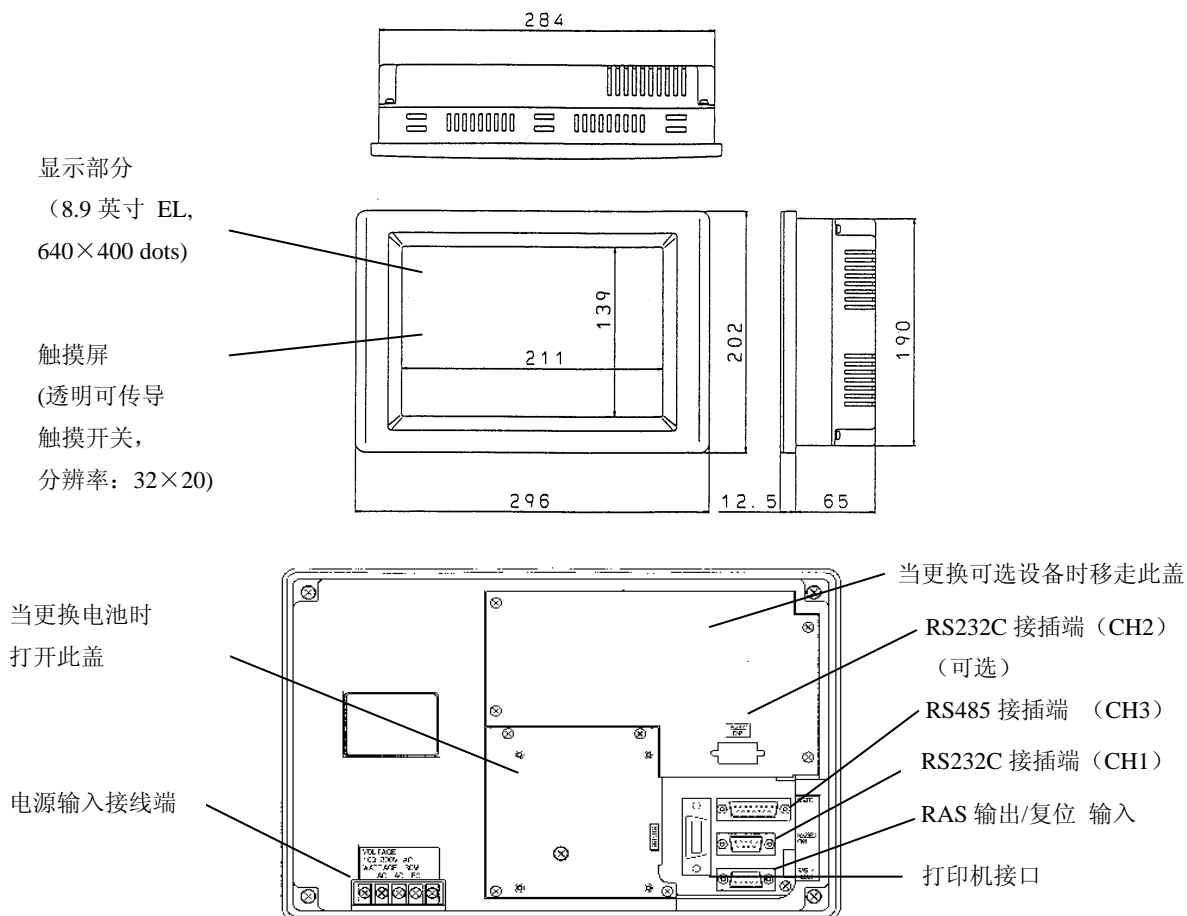

GC-53LC3-1 (彩色) / GC-53LM3-1 (单色)

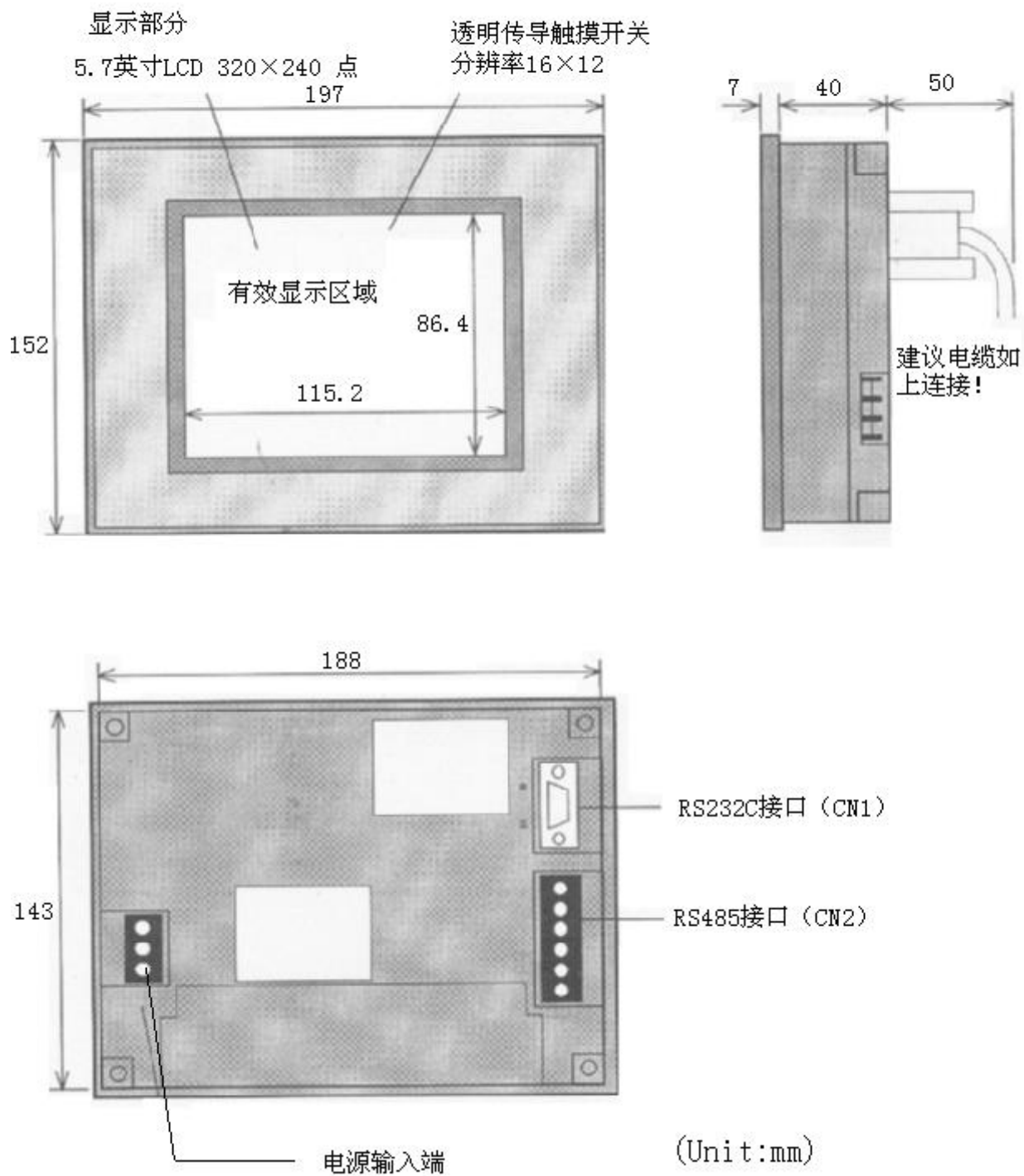

4. 一般规格

项目	GC-56LC2-1	GC-55EM2-1	GC-53LC3-1/GC-53LM3-1
振动	符合 JIS-C0911 标准 (5~55Hz, X,Y,Z 三轴 19.6m/s ² 两小时)		
耐冲击	符合 JIS-C0912 标准 (X,Y,Z 三轴 98m/s ² 12ms 以下)		
工作温度	0°C ~ 50°C		
环境湿度	无凝露 15% ~ 85%		
存放环境温度	-10°C ~ 60°C		
空气环境	无腐蚀性气体		
额定电压	AC85~264V	DC20.5V~28.8V	
额定频率	50~60Hz	—	
耗费电流	0.6~0.2A 以下 (AC85~264V)		
耗费功率	52.8VA 以下	14W 以下	
抗静电 (电源)	共模输入, 脉冲宽度 1500V _{pp} 。100ns~1000ns		共模输入, 脉冲宽度 1000V _{pp} 。100ns~1000ns
抗静电 (通信)	电容耦合, 脉冲宽度 500V _{pp} 。100ns~1000ns		
耐电压	GC-56LC2-1/ GC-55EM2-1: 电源输入端和接地保护端之间 1500VAC (一分钟) GC-53LC3-1/ GC-53LM3-1: 电源输入端和接地保护端之间 1000VDC (一分钟)		
绝缘电阻	GC-56LC2-1/ GC-55EM2-1: DC500V 时, 电源输入端和接地保护端之间 50MΩ 以上 GC-53LC3-1/ GC-53LM3-1: DC500V 时, 电源输入端和接地保护端之间 20MΩ 以上		
接地方法	等级 D		
安装结构	嵌入面板 (仅安装于前面板), 可以垂直或水平安装		
散热方法	自然空气对流散热		
IP 值 (防护性能)	符合 IP65F(前面板, 当使用衬垫时) 当经常接触水和油时, 需要加上保护膜 (选购件)		
重量	小于 2700g	小于 2500g	小于 850g
外部尺寸 (单位: mm)	GC-56LC2-1: 315(W)×240(H)×72.5(D) GC-55EM2-1: 296(W)×202(H)×77.5(D)		197(W)×152(H)×47(D)
有效显示区域 (单位: mm)	211.2(H)×158.4(V)	191.9(H)×119.9(V)	115.2(H)×86.4(V)

5. 显示器规格

项目	GC-56LC2-1	GC-55EM2-1	GC-53LC3-1	GC-53LM3-1
显示器	TFT 彩色 LCD	高亮度 EL	彩色 LCD	单色 LCD
显示点数	640×480 点	640×400 点	320×240 点	
点间距	0.33×0.33mm			
有效显示尺寸	10.4 英寸(211.2×158.4mm)	8.9 英寸(191.9×119.9mm)	5.7 英寸(115.2×86.4mm)	
显示颜色、等级	262,144 色中 16 色	琥珀色	512 色中 16 色	青色
背光灯	冷阴极管，可更换			
辉度调整	8 级对比辉度调整（用触摸键调整）			
视角	typ 30 度、typ 20 度、typ 45 度 常温（25℃±5℃） 对比度：10：1 以上的范围			
显示面辉度	参考：typ 200cd/m ²			
显示面板对比度	参考：typ 150			
背光灯寿命	20000 小时，无日光直射、无振动冲击、常温（25℃），低温时（5℃以下）有可能为标准寿命的 1/20。			

6. 显示功能规格

项 目	规 格			
显示器	GC-56LC2-1	GC-55EM2-1	GC-53LC3-1	GC-53LM3-1
显示文字种类	半角：英文、数字、假名等 158 种 全角：非汉字 606 文字 汉字 6355 种 JIS 第一标准和第二标准			
文字尺寸	半角：8×16 点 全角：16×16 点 文字放大倍数：横 1、2、4、8、16 倍 竖 1/2、1、2、4、8、16 倍			
显示文字数	半角：80 字×30 行 全角：40 字×30 行	半角：80 字×25 行 全角：40 字×25 行	半角：40 字×15 行 全角：20 字×15 行	
文字属性	显示属性：普通、反色、闪烁、点灭			
图形种类	直线型：直线、长方形、平行四边形、连续直线 曲线型：点、圆、圆弧、椭圆、椭圆弧、曲线 其它：着色、位图、多角形涂色			
图形属性	线种：实线、 其它 5 种 填充模式：16 种	线种：实线、 其它 5 种 填充模式：2 种	线种：实线、 其它 5 种 填充模式：16 种	线种：实线、 其它 5 种 填充模式：2 种
	表示属性：普通、反色、闪烁、点灭 透明处理：可以			

7. 触摸面板规格

项目	GC-56LC2-1/ GC-55EM2-1	GC-53LC3-1/ GC-53LM3-1
分辨率	32×24 键	16×12 键
方式	矩阵式透明电阻膜式	
寿命	100 万次以上	
单元尺寸	5.6×5.6mm	
标准操作力	3.0±1.0N	

8. 功能/性能规格

项目	GC-55EM2-1/GC-56LC2-1	GC-53LC3-1/GC-53LM3-1
登录画面数	(最大) 1024 个	
用户程序存储器	FlashROM: 3MB(画面和程序)	FlashROM: 1MB(画面和程序)
系统存储器	512K Bytes (注 1)	
后备存储器	256K bytes (仅当装有电池时)	
画面表示方式	取决于部品的表示及控制	
登录部品数	999 个/画面 (最大)	
开关动作方式	点动、返转 (ON/OFF)、自动翻转	
可设定显示器数	1024 个/部品 (最大)	
可设定显示器种类	数据显示器、文字显示器、时钟显示器、图形显示器、 指示灯、开关、键盘、仪表、管子、棒形图、图表曲线、饼状图、趋势图、 报警等等	
时钟、日历显示	时钟、日历功能: 有 停电记忆功能: 有 日历精度: ±40 秒 (每月) (Ta=25℃)	
画面打印功能	有 (注 2)	
蜂鸣器	ON、OFF	
自诊断功能	系统情报、通信口、表示色、键输入	

注:

- 1) 实际可以使用的存储器约为 400KB
- 2) 对应于 PCPR201,ESC/P.
不能使用 Windows 专用打印机, 可以使用并行或串行打印机。
- 3) 当显示电池电压低下时, 请尽快更换电池。
另外, 即便不显示报警时, 当电源连续未上电时间超过 5 年时, 请无条件更换电池。

9. 编程环境

项 目	规 格
编程方式	按照编程软件
编程工具	编程软件：SCREEN CREATOR 5(高于 Ver2.22) 个人计算机名：Windows95/98 可工作 操作系统：Windows95/98 注) Windows NT(高于 Ver.4.0)也可，但不能保证。 内存要求：16MB 以上 硬盘剩余容量要求：170MB 以上（簇大小 32KB；FAT16） 40MB 以上（簇大小 4KB；FAT32） 输入设备：键盘、鼠标 其它：需要能显示 256 色以上的显示器

10. 软件规格

种类	内容	程序品目号	版本
软件程序	系统程序由我 公司写入	CR21-54-R605 以后	GC-56LC2-1/ GC-55EM2-1 XX2.42 以后
			GC-53LC3-1/ GC-53LM3-1 XX2.31 以后
画面数据程序	画面需要显示 的内容由用户 输入	由用户管理	由用户管理

11. 安装步骤

注意：

- 确保面板被安装在符合产品一般规格的环境里。避免在以下场所使用本装置：
 - 环境温度或相对湿度超出一般规格范围的场合。
 - 环境温度易发生突变从而可能产生凝露的场合。
 - 存在大量易燃易爆性气体或溶剂和流体的场合。
 - 环境中有过量尘埃、盐或金属颗粒的场合。
 - 可能直接受到大幅振动或撞击的场合。
 - 有日光长期照射的地方。
 - 存在会产生强烈静电干扰的机械和设备的场合。

11-1 安装

可以垂直或水平安装。

11-1-1 面板安装孔径（单位：mm）

(1) GC-56LC2-1/ GC-55EM2-1

① 水平安装

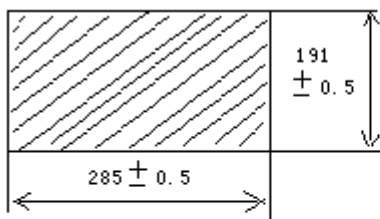

② 垂直安装

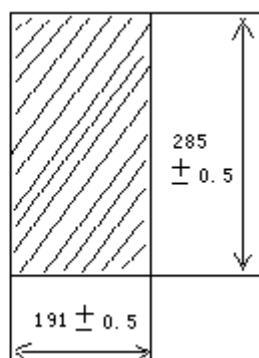

(2) GC-53LC3-1/ GC-53LM3-1

① 水平安装

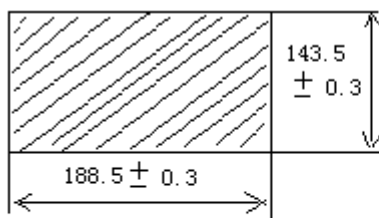

② 垂直安装

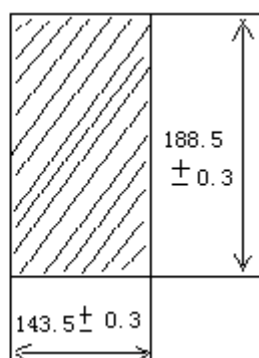

11-1-2 衬垫的安装

衬垫位于面板和 OIP 前面板之间，以防止油或水进入面板内部。

① GC-56LC2-1

将衬垫（“V”形圈）安装在 OIP 前面板后面的凹槽里，示意如下：

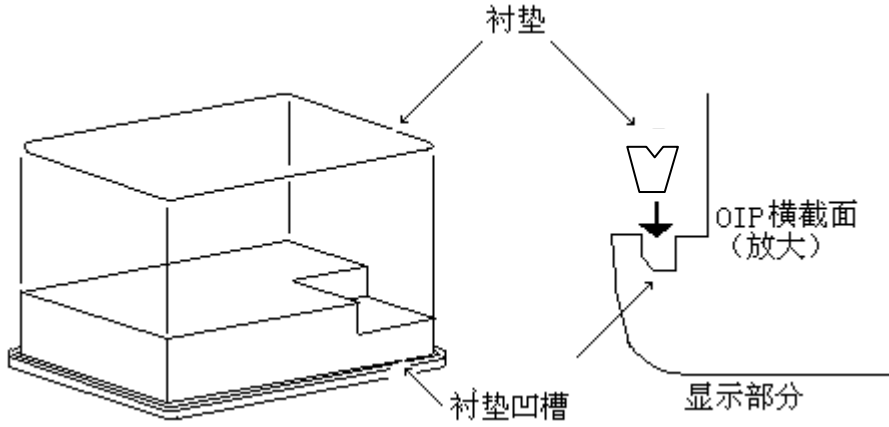

② GC-55EM2-1

将衬垫（“V”形圈）安装在 OIP 前面板后面（该部分将与面板接触），如下图所示：

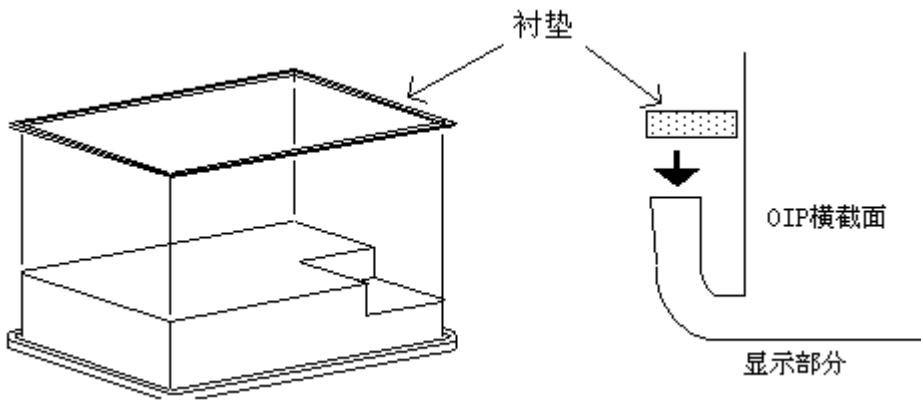

③ GC-53LC3-1/ GC-53LM3-1

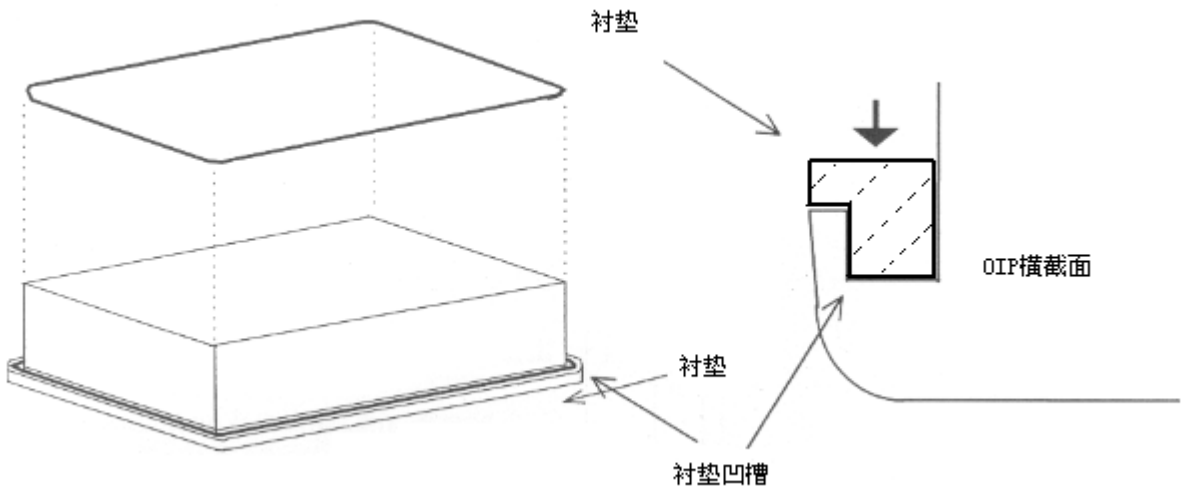

11-1-3 OIP 的安装

1. 从正面将 OIP 插入面板内，然后从面板的后面装上夹具，将 OIP 固定在面板上。
如果你所用的是 GC-56LC-1，请注意将衬垫正确地放在 OIP 的沟槽里；如果是 GC-55EM-1，请不要让衬垫的边缘露到 OIP 的外面，也别让其在 OIP 里面折叠着。

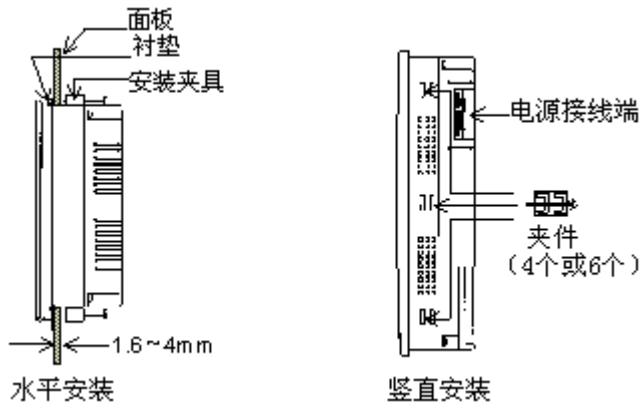

注意

- 1) 面板厚度应在 1.6~7mm 之间。
 - 2) 使用 4 或 6 个固定夹具。
 - 3) 使用 0.3~0.5Nm 的力矩拧紧夹具上的螺丝。并保证 OIP 与面板恰好接触，拧得太紧会使 OIP 外壳变形或损坏。
 - 4) 当 OIP 水平安装时，要确保电源接线端位于上方。
 - 5) 安装表面必须平整，否则，即使是使用了衬垫也达不到 IP65F 的标准。
 - 6) 因为 GC-56LC2-1 使用彩色液晶显示器，最理想的视角是有限制的。
虽然，最佳视角可以随着系统模式屏幕设置作微小调节，但调节是有限度的。安装时应先考虑好安装位置和视角。
2. 采用竖直安装的前提是有供散热用的自然流动空气。
如果本产品被安装在一水平面上，则要采用强风散热，以使 OIP 不至于急速升温。



3. 请留有足够的通风空间，以使 OIP 散发出的热量不至于散发不出去。
基本指导方针是使 OIP 与其它设备、装置、平面的距离保持 100mm 以上。
4. 将 OIP 安装在不至于被其它装置加热的地方。

11-1-4 安装夹具尺寸（单位：mm）

① GC-56LC2-1/GC-55EM2-1

② GC-53LC3-1/GC-53LM3-1

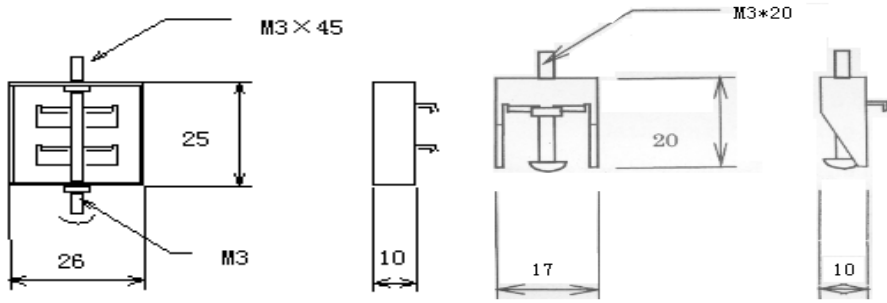

11-2 电源

请按照下述说明连接电源线。

1. 当电源电压变动超过允许值时，请使用可调电源变压器。

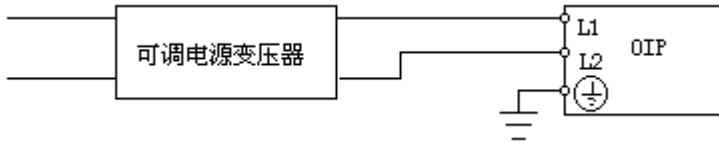

2. 请给 OIP 和电动设备或输出设备使用不同的电源线。

① GC-56LC2-1/GC-55EM2-1

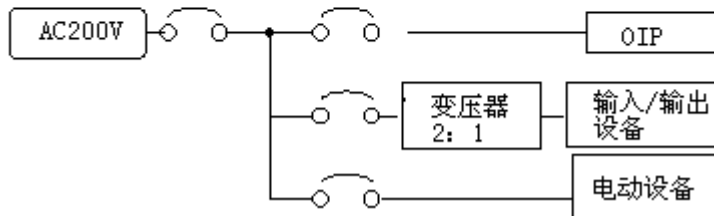
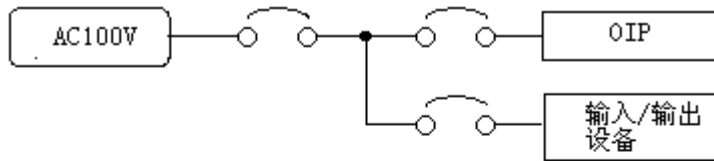

② GC-53LC3-1/GC-53LM3-1

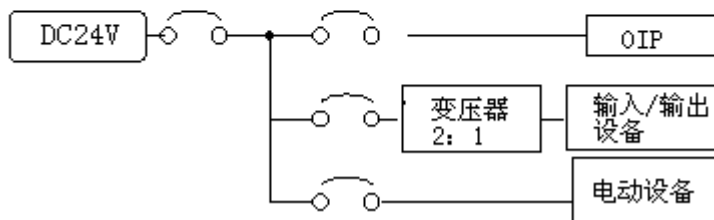
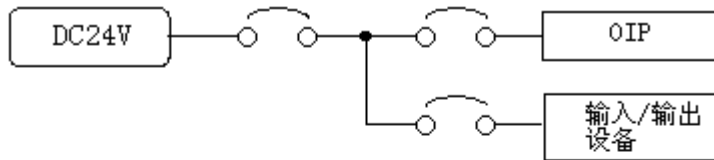

3. 如果电源线存在大的噪声，请使用隔离变压器。(GC-56LC2-1/GC-55EM2-1)

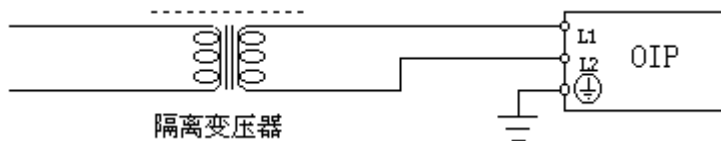

4. 务必将电源线与高压线、马达电源线、还有输入/输出信号线分开，距离至少 200mm。
5. 用 0.79Nm 的力矩拧紧电源接线端螺丝。

11-3 接地

为了防止电击事件的发生，请使用专用接地线（接地电阻小于 100Ω）

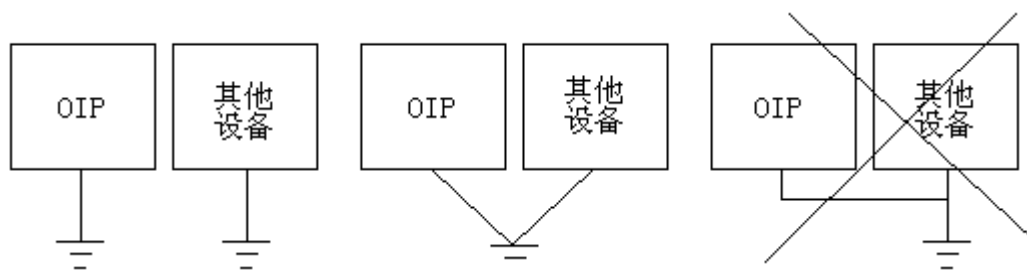

用一根横截面积为 $0.75 \sim 2\text{mm}^2$ 的导线作接地线。

11-4 其他连接方式

将所有的 RS232C、RS485 通信线、RAS 输出线和复位输入线与电源线、高压线、电动机电源线和输入/输出信号线的隔离至少 200mm。

12. 通信协议规格

在本装置上设定可与每个通道进行通信的机种（如上位机、PLC 等），通信需要的协议用作画的工具可与画面等数据一同下载使用。

12-1 指令通信

根据使用专用的串行通信指令，可连接通用计算机及专用控制器。在指令通信时，本装置为从机。

12-1-1 指令通信的方法

在本装置和主计算机之间的通信，与从哪一方启动通信没有关系。状态转移图表示如下：

项目		A	B	C	D	E	F	G
状态		送信要求	受信正常	受信异常	受信数据无效	ACK 受信	NAK 受信	通信超时
1	空转状态	指令送信 →2	ACK 送信 →1	NAK 送信 →2	→1	忽略	忽略	—
2	等待指令送信后的相应	送信要求的登录	ACK 送信 →2	NAK 送信 →2	→2	→1	再试内： 再送→2 再试溢出： →1	再试内： 再送→2 再试溢出： →1

12-1-2 指令通信的数据结构

指令及响应的传输数据结构如下：

- 指令（上位计算机→本装置）

（253 比特以内）

开始代码	局号	对方计算机名 1	T 1	指令	数据	T 2	……	对方计算机名 n	T 1	指令	数据	终了代码	SUM	结束
------	----	----------	-----	----	----	-----	----	----------	-----	----	----	------	-----	----

- 指令（本装置→上位计算机）

（253 比特以内）

开始代码	局号	数据	终了代码	SUM	结束
------	----	----	------	-----	----

- 应答指令

（正常）

ACK	局号	结束
-----	----	----

（异常）

NAK	局号	结束
-----	----	----

名称	内容	必要性	数据长度	范围	初始值
开始代码	传输组的开始代码	○/×	1 字节	01~7FH	02H
局号	本装置的局号	○/×	2 字节	00~FF (ASCII 码)	未使用
对方名	画面名及部品名	○	—	—	—
T1	对方名结束	○	1 字节	01~7FH	01H
指令	指令	○	1 字节		—
数据	送到对方的数字及文字数据	○			—
T2	发送给对方的一个数据结束	○	1 字节	01~7FH	04H
终了代码	发送数据的结束码	○	1 字节	01~7FH	03H
SUM	校验和： 把“开始代码”到“结束代码”之间之间的数据以八位为单位相加，然后取其补码。	○/×	2 字节	—	有
结束 1	传送数据结束 1	○	1 字节	01~7FH	0DH
结束 2	传送数据结束 2	○/×	1 字节	01~7FH	0AH
ACK	正常应答	○	1 字节	01~7FH	06H
NAK	异常应答	○	1 字节	01~7FH	15H

注) 标有“○”的项目为必须项目;

标有“○/×”项目可以通过通信格式的设定, 来选择使用或不使用。

12-1-3 指令通信的数据格式

送信的数据结构按以下规则

- 代码以及结束码等的数据的值必须各不相同。另外, 在传输组内的数据块中不能含有与这些相同的值。
- 局号、对方名、数据及校验和 (SUM) 请用 ASCII 码形式送信。因此, 数据也需要变换成 ASCII 码形式。
- 在一个数据中, 可放入多个情报送信。此时, 在数据和数据之间用“,” 隔开。另外, 作为数据, 其标点符号“,” 不可送信。

12-2 存储器链接通信

“存储器链接通信”的方式通过本装置的记忆空间 (存储器表), 可进行数据的送、受信。

与指令通信相同, 与上位计算机及专用控制器的连接, 本装置作为从机。

12-2-1 存储器表的构成

在本装置的内部存储器中, 为数据的送受信准备了如下存储器表:

系统参数区
用户数据区

存储器表 (Memory Table):

- 代号: MTBL(XXXX) 其中, XXXX=0~8191
- 数据: word (2 字节)
- 容量: 8192 个字

地址 MTBL(0) ~ MTBL(15) 为系统参数区

MTBL(16)~MTBL(8191) 为用户数据区

12-2-2 功能

采用本方式可使用的功能如下表, 各功能(指令)用 ASCII 码形式表示。

	类型 1	类型 2
主机→给本装置的命令	<ul style="list-style-type: none"> • 向存储器表写入(以字为单位、以比特为单位) • 从存储器表读出(以文字文单位) 	<ul style="list-style-type: none"> • 向存储器表写入(以文字为单位、以比特为单位) • 从存储器表读出(以文字文单位)
本装置→给主机的命令	<ul style="list-style-type: none"> • 可以把写入到表号 0 中的数据用一个字节的 2 进制单独给主机送信。 • 对于来自主机的指令的正常/异常反应不反馈(对于读出指令的数据反馈) 	<ul style="list-style-type: none"> • 用指令形式把写入表号 0 中的数据传给主机 • 用指令形式把写入表号 1、2 中的数据进行送信 • 对来自主机的指令的正常/异常反应要反馈。

12-2-3 传输组结构

指令的传输组结构如下：

E S C	局号（可省略）	指令	参数 1	参数 N	C R
-------	---------	----	------	-------	------	-----

12-3 无协议通信

“无协议通信”使用 GC 内部的 K-BASIC 程序来编写通信协议的通信方法。如与 Modem 相连，使用 AT 指令（Modem 协议）可与公共回线连接。用 K-BASIC 编写的通信程序与用户画面数据同时下载到触摸屏。

在通信时，本装置（OIP）既可作为主机也可作为从机使用。

12-4 直接通信

“直接处理”方式就是在显示器上将需要的数据等对 PLC 进行直接处理的方法。把本装置作为主机使用，配合从机 PLC 侧的协议，可以直接连接需要读取的存储器数据，故在 PLC 侧不需要为通信编写程序。另外，本装置内部内置了可连接的 PLC 协议，在作画时只要选择了相应的 PLC，其协议便可与画面数据同时下载。

12-5 其它通信方式

本装置还可以与条形码读入机等连接。但由于准备好了协议，故在作成画面时，可与画面数据同时下载。

13. 接口性能

13-1 RS232C（CH1,CH2）

1. 传输性能

No.	项目	说明
1	通信方法	全双工
2	同步	启动—停止同步
3	传送距离	15m
4	连接类型	1: 1
5	传输速率	1200, 2400, 4800, 9600, 19200 和 38400bps (在设置通信参数时设定)
6	数据格式	起始位: 1 位 停止位: 1 位或 2 位 数据长度: 7 位或 8 位 校验方式: 奇、偶或无校验 (在设置通信参数时设定)

2. 接插件针脚号及其信号

- CH1,CH2 (CH2 为选件)

针脚号	信号	方向	说明
1	FG		接地保护端
2	SD	输出 (Output)	数据发送端
3	RD	输入 (Input)	接收数据端
4	RS	输出 (Output)	数据发送请求信号
5	CS	输入 (Input)	接收许可信号
6	未定义		
7	SG		信号地 GND
8	未定义		
9	+5V		5V 电源 (供可选设备用)

※CH2 的 RS 与 CS 在 OIP 内部相连

3. 接插件针脚图 (OIP)

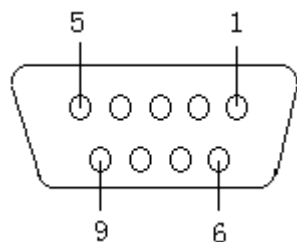

D 型接插件 (孔型)

- 可用接插件

插头: XM2A-901(OMRON)或等效的其它产品

外壳: XM2S-0911(OMRON) 或等效的其它产品

13-2 RS422 (CH3)

1. 传输性能

No.	项目	说明	
1	通信方式	全双工, 5 线	半双工, 3 线
2	同步方式	启动-停止同步	
3	传输距离	500m (总长)	
4	连接方式	1: N(N≤32) N:PLC 数量	M:N(M+N≤32) M:OIP 数量 N:PLC 数量
5	传送数率	1200, 2400, 4800, 9600, 19200 和 38400bps (在设置通信参数时设定)	
6	数据格式	起始位: 1 位 停止位: 1 位或 2 位 数据长度: 7 位或 8 位 校验位: 奇、偶或无校验 (在设置通信参数时设定)	

2. 接插件针脚号及其信号

GC-55EM2-1/GC-56LC2-1:

针脚号	信号	方向	说明
1	RD-	输入	接收信号（-）
2	(CTS)	输入	允许接受信号
3	SG1	——	信号地（GND）
4	SD-	输出	传送数据（-）
5	SD-	输出	传送数据（-）
6	SG2	——	信号地（GND）
7	(RTS)	输出	传送请求信号
8	RD-	输入	接收数据（-）
9	RD+	输入	接收数据（+）
10	FG1	——	保护接地
11	SD+	输出	传送数据（+）
12	(+5V)	——	5V 电源（供可选设备用）
13	SD+	输出	传送数据（+）
14	FG2	——	保护接地
15	RD+	输入	接收数据（+）

注意：CTS,RTS 和+5V 仅用于扩展，不能用于 RS485。

GC-53LC3-1/GC-53LM3-1:

针脚号	信号	方向	说明
1	SD+	输出	传送数据（+）
2	SD-	输出	传送数据（-）
3	RD+	输入	接收数据（+）
4	RD-	输入	接收数据（-）
5	SG	—	信号地（GND）
6	FG	—	保护接地

3. 接插件针脚图（OIP）

GC-56LC2-1/GC-55EM2-1：接插件为两排 15 孔插座。

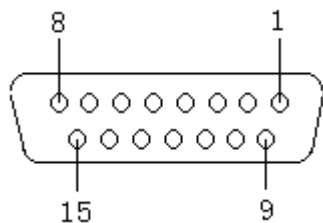

D形接插件（孔型）

可用接插件：

插头：XM2A-1501(OMRON)及其它等效产品

外壳：XM2S-1511(OMRON)及其它等效产品

GC-53LC3-1/GC-LM3-1: 其 RS422 口为接线端子排。



4. 内部电路

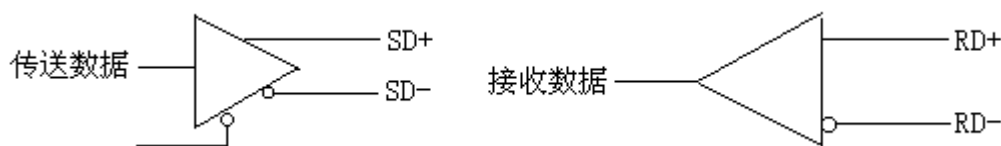

注意: 末端电阻不是内置的, 所以, 如果有必要在末端板上外加一电阻.

13-3 打印口 (仅 GC-56LC2-1/GC-55EM2-1)

1. 接插件针脚及其信号

针脚号	信号	针脚号	信号
1	STB	8	D6
2	D0	9	D7
3	D1	10	-
4	D2	11	BUSY(忙)
5	D3	12	-
6	D4	13	-
7	D5	14	GND

- 打印电缆
PC-8894(NEC)及等效产品
- 打印机
支持对应于 PCPR201,ESC/P 的兼容机型, 不支持 Windows 专用打印机。

2. 接插件针脚图 (OIP)

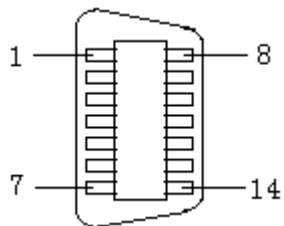

- 可用接插件
57K-3014S(DDK)获等效产品

13—4 RAS/Reset（仅 GC-56LC2-1/GC-55EM2-1）

1. 接插件针脚及其信号

针脚号	信号	方向
1	RAS+	系统错误输出（+）
2	-	
3	-	
4	-	
5	RST+	外部复位输入（+）
6	RAS-	系统错误输出（-）
7	-	
8	-	
9	RST-	外部复位输入（-）

2. RAS

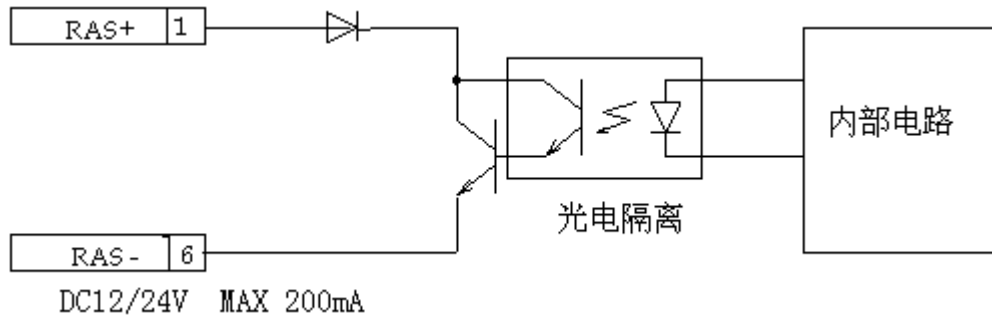

3. 复位信号（RST）

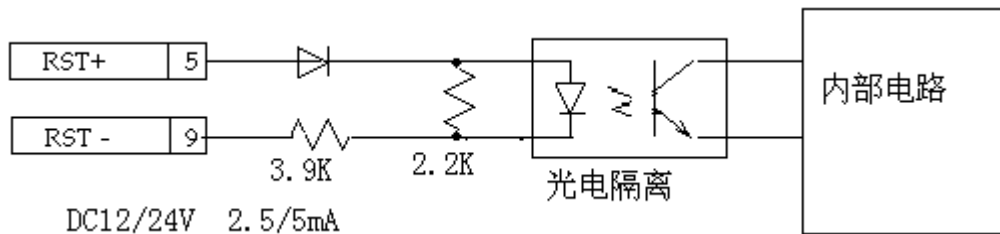

4. 接插件针脚图（OIP）

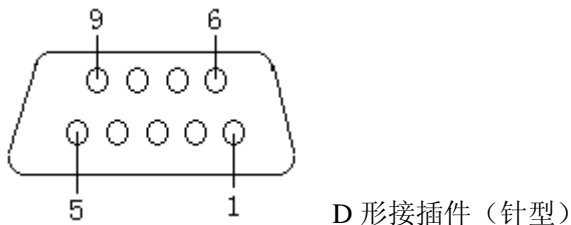

可用接插件：

插头：XM2D-0901(OMRON)或其它等效产品

外壳：XM2S-0911(OMRON)获其它等效产品

13—5 使用 5V 电源（可选）时请注意

可以从 RS232C(CH1),RS232C(CH2)和 RS485(CH3)端口获得的最大总电流为 300mA。请不要超过这个范围！

14. 操作准备

14-1 系统语言设定

为 OIP 系统屏幕和出错信息显示选择一种语言，可以是日语或英语（注意：一旦设定好，就不可更改）！（中文版系统请选择英语，可以支持中文字体显示。）

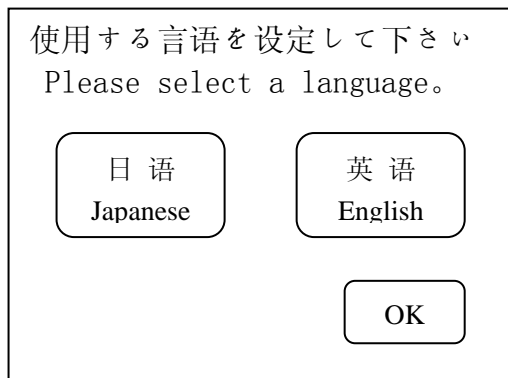

如果确实必须更改，请参考 14-3-9 系统语言设定

14-2 画面下载

使用提供的可选下载电缆（GC-S1C1-DEE）来下载。

关于下载电缆的内部接线，请参考第 19 章。

当 OIP 还是首次使用，用户屏幕数据还没有下传，这时只要一上电，就会显示系统模式屏幕菜单。按照如下程序下载：

- 1) 将下载电缆与 RS232C 接插口（CH1）连接好，系统参数将会自动设置。
- 2) 从系统模式菜单选择下载后，OIP 将显示下载屏幕，并且等待通信。
- 3) 启动触摸屏画面编辑软件“SCREEN CREATOR 5”，执行“Downloading”（下载）。
参考《GC 触摸屏编辑软件 SCREEN CREATOR 5 使用手册》。
- 4) 要取消下载，请按屏幕上的 Cancel 键。
当下载启动后，若按取消（下载）键，已经下载的内容将被全部清除。
- 5) 当下载完毕，屏幕上将显示正常结束屏幕，显示“OK”。

6) 在按下“OK”键后，屏幕将返回主菜单。选择用户模式（User mode），系统将开始运行。

当用户数据已经被下载到 OIP 单元后，在上电时将不再进入系统模式，而是直接进入用户模式。

因此，如果需要再对已下载的数据作改动，请按照 14-3 节所述步骤进入系统模式画面。

14-3 系统设置

有两种方法可将 OIP 切换到系统模式画面。

- 如果 OIP 是横着（水平）安装，按住屏幕左上方；但如果是竖直安装，应按住屏幕左下方，然后上电。
- 当屏幕显示处于用户模式时，不管 OIP 如何安装，同时点击左上方和右下方的按钮。如果屏幕数据尚未下载，上电时将直接显示系统模式画面菜单。

上电时切换到系统模式画面的方法：

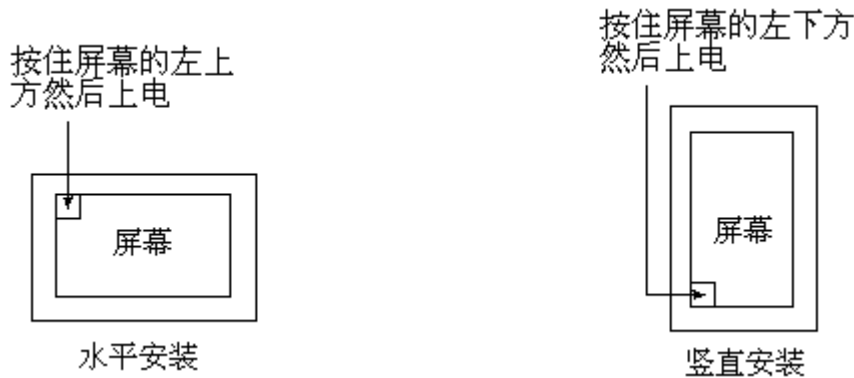

从用户模式切换到系统模式画面的方法：

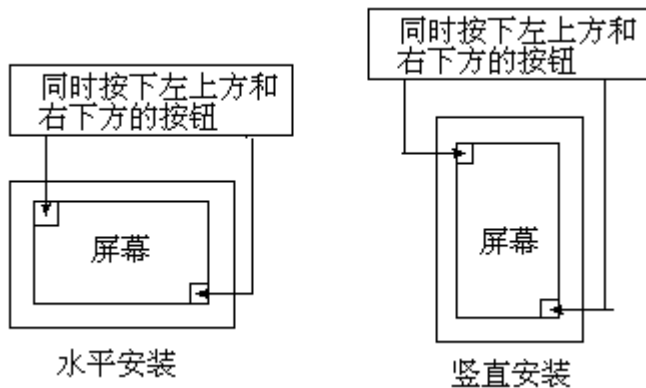

在做了以上操作后，GC 画面便进入系统模式画面。

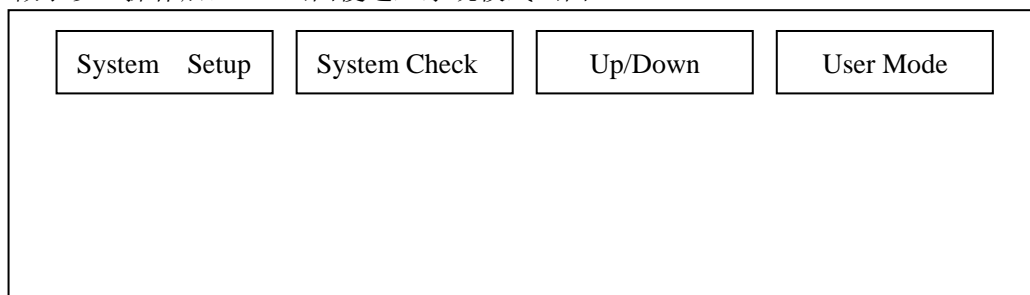

注：在每个画面上，“RET”表示 ENTER(确定)；“ESC”表示 cancel(取消)。

此时，按 **System Setup** ，进入系统参数设置画面；

按 **System Check** ，进入系统自检画面；

按 **Up/Down** ，进入用户画面数据上传 / 下传状态；

按 **User Mode** ，进入用户画面显示状态。

14-3-1 通信端口设定

为各种通信端口设置通信类型和通信参数：

- 1) 在系统模式画面，选择“System Setup”，进入系统参数设置画面。

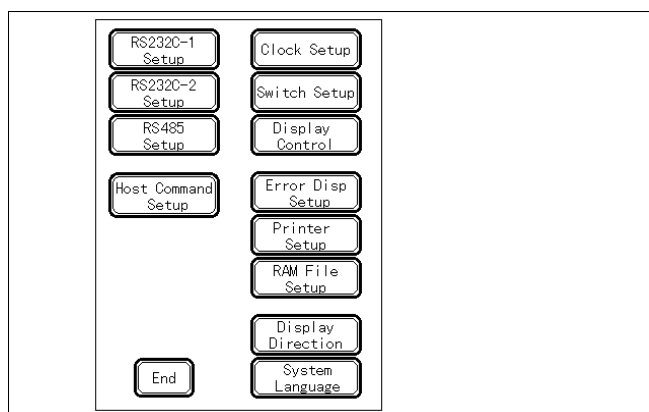

- 2) 在这儿选择要设置的通信端口，系统显示对应端口的参数设置画面，这时你可以设置各个参数（包括通信类型，通信速率，校验方式，停止位及数据长度）

*注意：*如果“SCREEN CREATOR 5”没有所连接装置的设置项，那么就不能设置该通信类型。

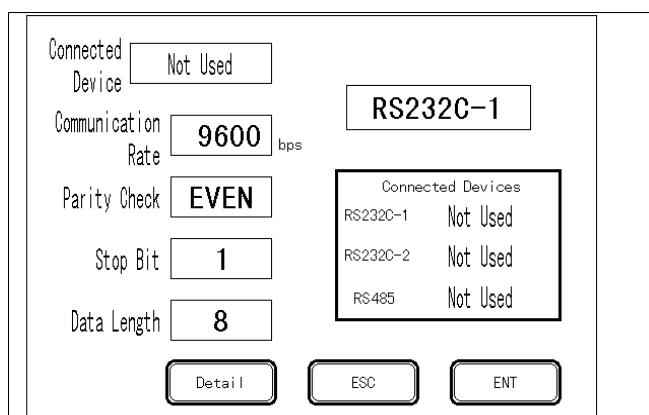

3) 点击连接设备项，则弹出连接设备选择画面，此时，可选择所连接的设备。

注意：如果所选择设备的通讯协议还没有随画面数据一起传入 GC，则系统忽略你的选择！

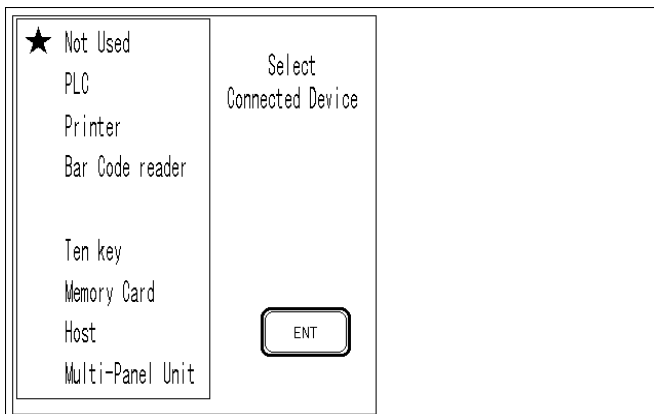

4) 按“ENT”键，返回通讯参数设定画面，这儿，你可详细设定对应通讯口的通讯参数。按“Detail”键，可进入通讯超时、X-ON/OFF控制选择和重复次数的选择画面；

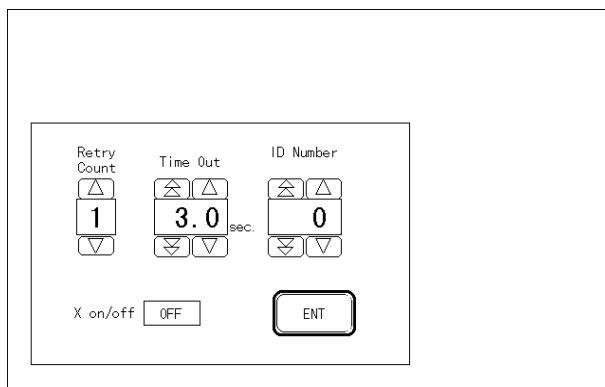

按“ESC”键，系统忽略你对所选择通讯口的设置，返回参数设置画面；

按“ENT”键，系统接受你对所选择通讯口的设置，并返回参数设置画面。

14-3-2 主计算机通信设定

当需要使用某种特定的串行通信协议时（主计算机命令方法或内存连接方法），就设置该通信数据形式。对内存连接方式仅局号项是有效的。

在系统设置画面，按“Host Command Setup”，则进入对主计算机通信参数设置画面。

14-3-3 日历和时钟的设定

在系统设置画面，按“Clock Setup”，则进入日历、时钟设置画面。

- 选定（或触摸）相应的项目（年、月、日、时、分），然后分别设置它们的值。
- 当设置结束，将秒自动设置为 00。

14-3-4 点击声音、允许同时按下键数设定

选择按钮被按下时是否发出“滴滴”声；以及允许同时按下键的总数。

在系统设置画面，按“Switch Setup”，则进入该设置画面。

14-3-5 显示控制

在系统设置画面，按“Display Control”，则进入显示控制设置画面。

① 显示关闭时间设定

该功能是：当在设定的时间内没有触摸信号输入时，屏幕显示将停止显示。

可以设置长达 60 分钟的显示关闭延时时间，设定间隔时间为 1 分钟。如果想让屏幕长期为显示状态，请将该值设置为 0。

② 辉度设置

屏幕辉度可以选择 8 种设置中的其中一种。

③ 视角调整（仅对 GC-56LC2-1）

在将本装置安装在面板上之后，将角度调整到在正常位置观看时相对最佳。当 OIP 中已下载有用户画面时，请针对相应的用户画面将视角调整到最佳位置。

14-3-6 错误信息显示设置

在系统设置画面，按“Error Disp Setup”，则进入错误信息显示设置画面。

选择错误信息（由于用户程序而产生的错误）的显示方式（在屏幕下方或在一窗口里面）：

屏幕下方：错误信息及四位数字错误代码将显示在屏幕下方。

窗口显示：错误信息将显示在创建屏幕时指定的出错显示单元里面。

这些设置仅对错误代码在 4000~4499 及 5000~5999 之间的出错有效。

14-3-7 打印机设置

在系统设置画面，按“Printer Setup”，则进入打印机设置画面。

当使用打印机时，请设定与此相关的“输出端口”，“打印协议”，“画面打印模式”以及“打印超时时间”各项设定。

在画面的硬拷贝打印中，开关动作、显示内容的更新、画面的切换等功能将不能实施。

14-3-8 RAM 文件的设定

设定在把系统 RAM 作为 RAM 文件使用时的容量。可使用的范围受到系统 RAM 容量和画面数量的限制。当不使用 RAM 文件时，务必把容量设置为 0。

14-3-9 显示方向设置

在系统设置画面，按“Display Direction”，则进入显示方向设置画面。

该设置决定 OIP 是横向使用还是竖直使用，这时不仅用户画面显示方式、系统和错误显示方式也将随之变化。

14-3-10 系统语言设置

在英语和日语之间选择一种（中文版请选择英语，此时可以进行中文输入和显示）。

注意：除显示方向之外，其它设置数据都在 GC 进入用户模式时存储在 Flash ROM 里面。所以，在设置完成之后，务必点击“用户模式”按键，。

14-4 操作前

首次开始操作前，请核查如下项目：

- 屏幕数据是否已经正确下载？
- 是否已经正确地进行了各种系统设置？
- 接插件连接是否正确？
- 供电电源是否正确？
- 各种连接是否正确？

15. 电池

OIP 里面有一个钮扣式锂电池，供内部时钟和内存保持之用。

注意

当显示电池电压偏低时，请立即更换电池！

当 OIP 未通电时间超过 5 年时，请立即更换电池！这时不管电池电压指示如何！

15-1 电池类型

注意：

请使用钮扣式锂电池（Toshiba CR2025）

15-2 如何更换电池

注意： 上电后，在更换电池以前至少再等 5 分钟，以便使内部电容充上足够的电来保持内存内容。

- 1) 切断电源，并拆掉接线端电源线。
- 2) 拆开本装置后板上面的电池盖。
- 3) 取走旧电池换上新电池。

注意：

千万别将电池的极性接反

- ① 在 3 分钟之内完成更换电池的操作。
- ② 别让电池掉入 OIP 里面。

如何拿走电池

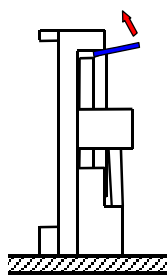

将手指或细棒插入狭缝里，然后向上提起电池。

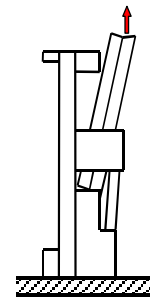

将电池滑出电池挡板

如何安装电池

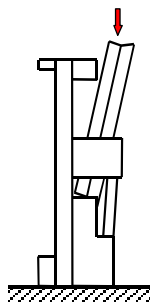

外面为+

将电池滑进电池夹

- 4) 安装电池盖并拧紧螺丝。

16. 背光灯（GC-55EM2-1 无）

- 在下述条件下使用背光灯将会降低其辉度，缩短其本身寿命。
 - 环境温度太低（低于 5℃）
 - 背景灯开关太频繁。
- 背光灯的期望寿命是 20,000 小时，在室温条件下其寿命更长。但是，当长期工作在低温条件（低于 5℃）下，其寿命将可能缩短到原来的 1/20。
- 背光灯可由用户自己更换，背光灯备品型号：GC-S6BL-1。

17. 维护

- 触摸屏是玻璃制造的，所以当清理表面时不要用力过大。力量过大可能会使玻璃屏幕破碎。
- 不要让尖细的物体、有机溶剂、氨水及强酸接触屏幕。
- 要清洗面板和外壳，可用稀释后的中性洗洁剂或工业酒精浸过的抹布或棉布擦拭。
- 在使用稀释中性溶剂时，一定要将抹布充分拧干。
- 当使用保护膜时，在换下旧保护膜后，要立即贴上新的。
保护膜在购买本产品时是可选的。

18. 定期检查

每年要定期对 OIP 作一到两次检查。

在移动 OIP、对其作修改、或改变接线时，要检查如下内容：

	项目	说明	标准	措施
1	电源电压	测量电源输入端电压	在一般特性规定的范围之内	调整电源电压
2	周围环境	环境温度	在一般特性规定的范围之内	当 OIP 使用时是关在柜子里时，就得考虑柜子里的环境温度
		环境湿度		
		空气质量		
3	安装	安装螺丝是否松弛	没有松	拧紧螺丝
		接插件是否松弛	没有松	拧紧接插件螺丝
		电源输入端螺丝是否松弛	没有松	拧紧螺丝
		接线有无问题	断线或拉线过紧	改变接线
4	内部电池	确定更换时间	电源 OFF 时间：5 年	换电池



OPERATOR'S INTERFACE PANEL (OIP) INSTRUCTION MANUAL

Thank you for purchasing the Operator's Interface Panel.

Please read this manual before using the OIP so that you thoroughly understand its functions and how to use them.

If you need for detailed information, please contact your dealer or Koyo sales dept.

Important:

- Please keep this instruction manual in a place where it is available when necessary.
- The contents of this manual or the specifications of the OIP may be changed without prior notification.
- Care has been taken to assure that the contents of this instruction manual are correct, but if there are any doubts, mistakes or deletions, please notify our Sales Customer Support.
- Koyo is not responsible for any damages incurred as a result of using this manual, including any indirect damages.
- No part of this manual shall be copied, reproduced, or transshipped in any way without permission in writing from Koyo Electronics (WUXI) co.,Ltd.
- Koyo retains the exclusive rights to all information included in this document.

Warranty:

- If this product is used according to the instructions in this manual and a malfunction should occur within the warranty period, and Koyo admits the malfunction, then Koyo shall make any repairs or replacements free of charge.
- Koyo is not responsible for any damages or secondary damages incurred because of the malfunctioning of this product.

KOYO ELECTRONICS (WUXI) CO.,LTD.

Address: No.118 Lixi Road Wuxi, Jiangsu, P.R.China

Tel: (0510)85167888 Fax: (0510)85161393

Postalcode: 214072

Home page: <http://www.koyoele.com.cn>

CONTENTS

1.	SAFETY PRECAUTIONS	30
2.	CONTENTS	31
3.	NAMES AND FUNCTIONS OF THE VARIOUS PARTS	32
4.	GENERAL SPECIFICATIONS.....	34
5.	SCREEN SPECIFICATIONS	35
6.	DISPLAY FUNCTIONS	35
7.	TOUCH PANEL SPECIFICATIONS	36
8.	FUNCTIONAL SPECIFICATIONS	36
9.	PROGRAM ENVIRONMENT	37
10.	SOFTWARE SPECIFICATIONS.....	37
11.	INSTALLATION PROCEDURES	37
	11-1 Installation.....	37
	11-2 Power Supply	41
	11-3 Grounding	42
	11-4 Other Connections	42
12.	COMMUNICATION PROTOCOL SPECIFICATIONS	42
	12-1 Command Communication	43
	12-2 Memory Link Communication.....	44
	12-3 Non Procedure Communication.....	45
	12-4 Direct Access Communication.....	45
	12-5 Others Communication method.....	45
13.	INTERFACE SPECIFICATONS	46
	13-1 RS232C (CH1,CH2)	46
	13-2 RS422 (CH3)	47
	13-3 Printer (only GC-56LC2-1/GC-55EM2-1)	49
	13-4 RAS/Reset.....	50
	13-5 Notice for 5V power supply (Option).....	50
14.	OPERATION PREPARATIONS	51
	14-1 System Language Setting	51
	14-2 Screen Download	51
	14-3 System Settings	52
	14-4 Before Operation	56
15.	Battery	56
	15-1 Battery Type.....	56
	15-2 How To Replace The Battery.....	56
16.	BACKLIGHT (EXCEPT GC-55EM2-1)	57
17.	MAINTENANCE AND INSPECTION.....	58
18.	PERIODIC INSPECTION	58

1. SAFETY PRECAUTIONS

Be sure to follow the safety precautions listed below in order to use the OIP safely. Koyo cannot be held liable for any damages incurred if these safety precautions are not followed.

WARNING

- Design your system so that there are sufficient countermeasures for personnel accidents and major equipment accidents. The system should have an external protection and safety circuit, so that even if the OIP should malfunction or even if there is a defect in the program the safety of the system is assured.
- Do not use the touch panel of the OIP to make switches that are related to safety or people or major damages (emergency safety switches, etc.). Be sure the system is designed so that it can cope with any errors or malfunctions in the touch panel.
- Be sure that class D grounding is used for the protective grounding terminal. There is a possibility of electrical shock if the unit is not grounded.
- If the OIP should malfunction, immediately turn off the power and leave it alone.
- If there is direct output to external output devices such as PLCs, direct output will be driven regardless of the ladder circuit interlock. Output may be used to drive motors and the like, so avoid using direct output because it is dangerous.

CAUTION

- Use and store the OIP in the environment described in the specifications (regarding vibrations, shock, temperature, humidity, etc.).
- Do not use the OIP where it is subjected to inflammable or explosive gases, or steam.
- Before turning on the power, be sure that the power voltage rating of the OIP and the voltage rating of power supply match. Using a mistaken power supply can damage the unit.
- The protective grounding of the OIP and signal ground are connected internally. If any welding work is done on the OIP when it is built into another machine or control unit, the welding current may damage the OIP.
- Do not disassemble or modify the OIP. Doing so can cause malfunctions and lead to other problems.
- The OIP touch panel is made of glass. Striking it with hard objects or pressing hard on it may break the glass.

- Do not push down on the OIP touch panel with mechanical pencils, screw drivers or other sharp objects. Doing so can damage the touch panel or cause malfunctions.
- The backlight of the color LCD uses cold cathode tubes. When disposing of these, be sure to follow the disposal procedures prescribed by each local government.
- In order to prevent electric shock and burns when replacing the color LCD backlight, be sure to turn off the power and leave the unit alone until the internal temperature has decreased to room temperature. Also, be sure that any high voltages have been totally discharged.

2. CONTENTS

The following items should be in the cardboard container. Be sure to check that all items are included.

	GC-56LC2-1 (Color)		GC-55EM2-1 (EL)		GC-53LC3-1 (Color)		GC-53LM3-1 (monochrome)	
Name	Quantity	Model	Quantity	Model	Quantity	Model	Quantity	Model
Main OIP unit	1	GC-56LC2-1	1	GC-55EM2-1	1	GC-53LC3-1	1	GC-53LM3-1
Installation brackets	6	GC-S1BK-1	6	GC-S1BK-1	4	GC-S3BK-2	4	GC-S3BK-2
Packing	1	GC-S6PC-1	1	GC-S5PC-2	1	GC-S3PC-2	1	GC-S3PC-2
Instruction manual	1	ES-M0247	1	ES-M0247	1	ES-M0231	1	ES-M0231

3. NAMES AND FUNCTIONS OF THE VARIOUS PARTS

GC-56LC2-1(Color)

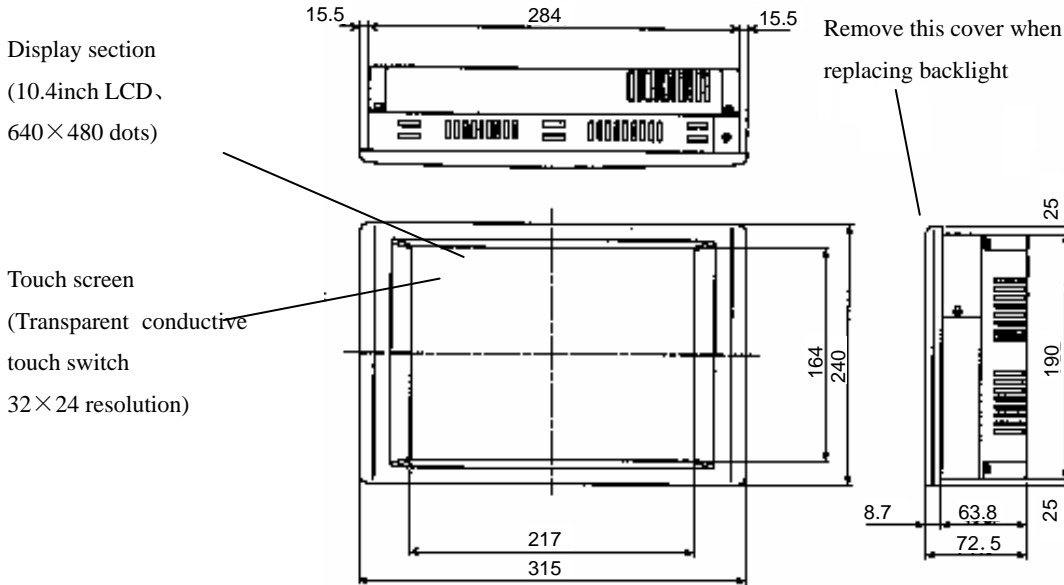

GC-55EM2-1(EL)

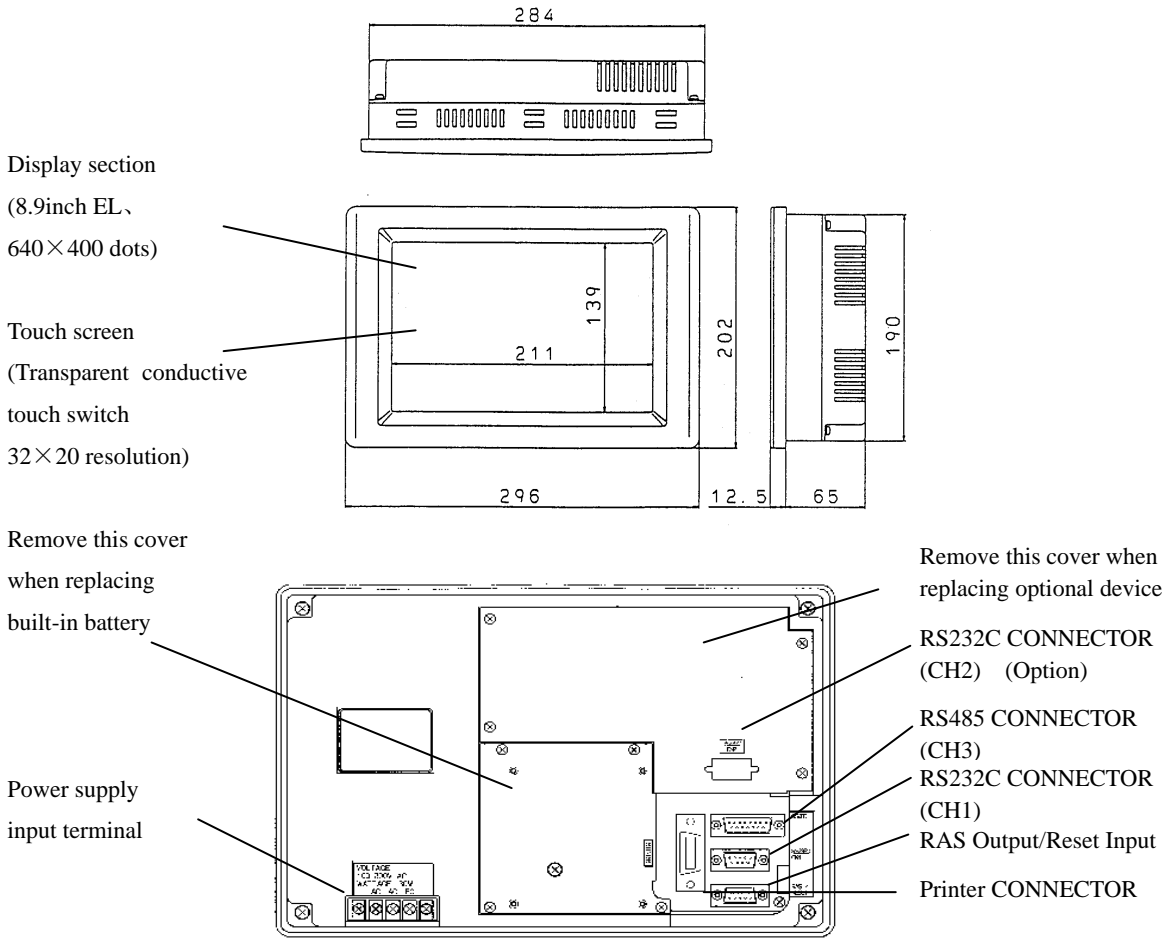

GC-53LC3-1 (Color) /GC-53LM3-1 (Monochrome)

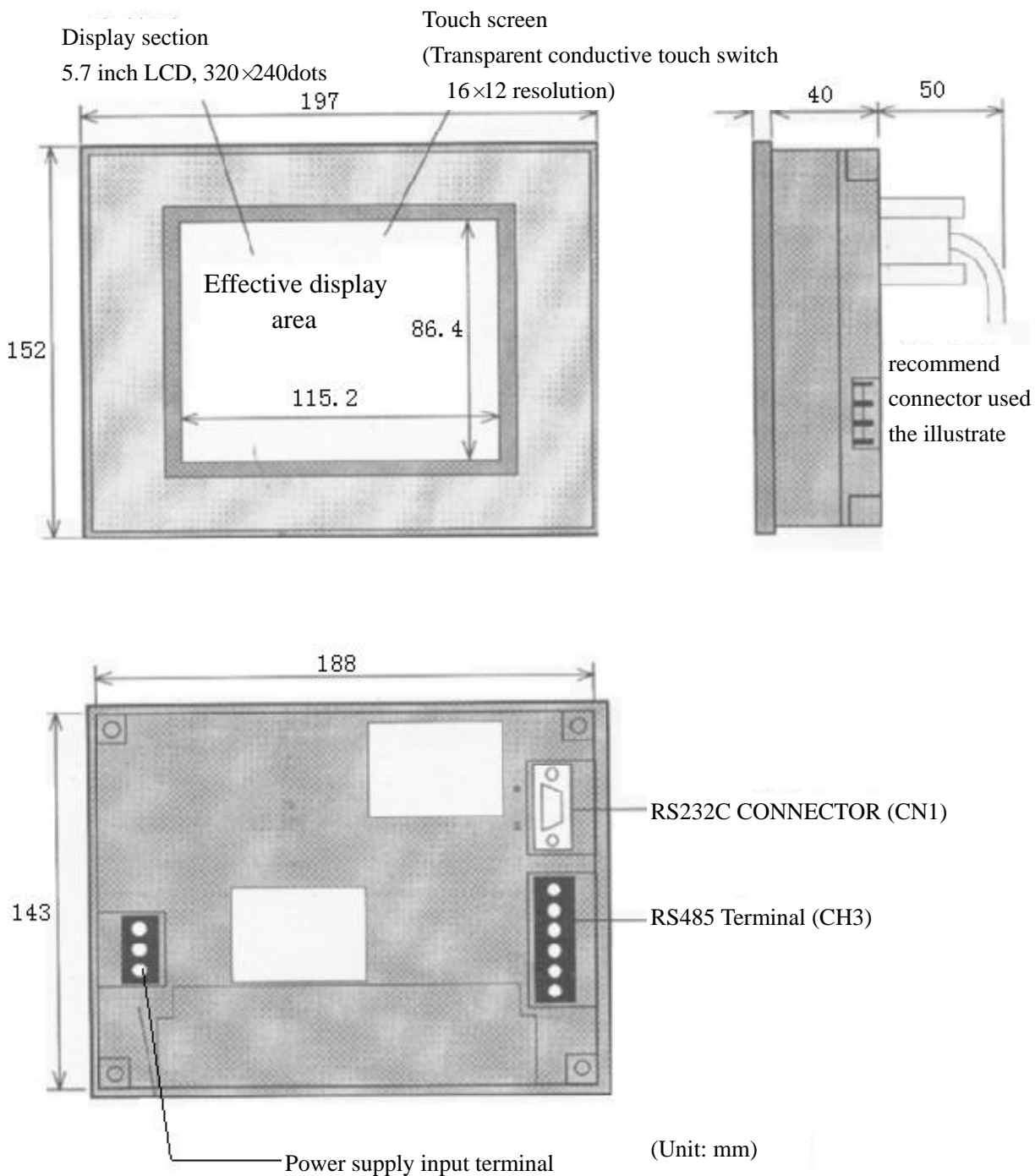

4. GENERAL SPECIFICATIONS

Item	GC-56LC2-1	GC-55EM2-1	GC-53LC3-1/GC-53LM3-1
Vibration	JIS-C0911 compliant (5~55Hz, 19.6m/s ² for two hours in the X,Y and Z axes)		
Shock	JIS-C0912 compliant (98m/s ² for under 12ms in the X,Y,Z axes)		
Operational ambient temperature range	0°C ~ 50°C		
Operational ambient humidity range	15 to 85 percent RH, no dew condensation		
Storage ambient temperature range	-10°C ~ 60°C		
Operational ambient atmosphere	No corrosive gas		
Power supply Rated voltage	AC85~264V	DC20.5V~28.8V	
Rated Frequency	50~60Hz	—	
Current consumption	Under 0.6~0.2A (AC85~264V)		
Power consumption	Under 52.8VA	Under 14W	
Static resistance (power supply)	1500V _{PP} pulse width,100ns and 1000ns common mode	1000V _{PP} pulse width,100ns and 1000ns common mode	
Static resistance (communications)	500V _{PP} pulse width,100ns and 1000ns capacity coupling		
Voltage resistance	1500VAC(one minute),between power supply input terminal and protective grounding	1000VAC(one minute),between power supply input terminal and protective grounding	
Insulation resistance	Over 50M-ohms at 500VDC, between power supply input terminal and protective grounding	Over 20M-ohms at 500VDC, between power supply input terminal and protective grounding	
Grounding method	Class D		
Structure	For building into panels(only to be installed in the front panel). Can be installed vertically or horizontally.		
Cooling method	Natural air cooling		
IP value	IP65F(front panel section when using packing) A protective cover is required when coming into regular contact with water or oil.		
Weight	Under 2700g	Under 2500g	Under 850g
External dimensions (Unit: mm)	GC-56LC2-1: 315(W)×240(H)×72.5(D) GC-55EM2-1: 296(W)×202(H)×77.5(D)	197(W)×152(H)×47(D)	
Effective display area (Unit: mm)	211.2(H)×158.4(V)	191.9(H)×119.9(V)	115.2(H)×86.4(V)

5. SCREEN SPECIFICATIONS

Item	GC-56LC2-1	GC-55EM2-1	GC-53LC3-1	GC-53LM3-1
Display type	TFT Color LCD	High brightness EL	Color LCD	Monochrome LCD
Resolution	640×480 dots	640×400 dots	320×240 dots	
Space between dots	0.33×0.33mm			
Display area	10.4 inches (211.2×158.4mm)	8.9 inches (191.9×119.9mm)	5.7 inches(115.2×86.4mm)	
Display color	16 Colors of 262,144 Colors	Amber	16 Colors of 512 Colors	Cyan
Backlight	cold cathode tube, User replaceable			
Brightness adjustment	8 levels from touch panel			
Angle of view	typ 30 angle、typ 20 angle、typ 45 angle Normal temperature (25°C±5°C) Contrast adjustment: above 10:1			
Display panel brightness	Reference: typ 200cd/m ²			
Display panel contrast	Reference: typ 150			
Backlight lifespan	The expected lifespan is about 20,000 hours or more at normal temperature (25°C), non-sunshine, non-vibration, non-shock, but it is reduced into 1/20 if the unit is used in low temperatures (below 5 degree C).			

6. DISPLAY FUNCTIONS

Item	Specifications			
	GC-56LC2-1	GC-55EM2-1	GC-53LC3-1	GC-53LM3-1
Display type				
Characters	8×16 dot font: English, number, kana, Total 158 classes 16×16 dot font: non-Chinese fonts 606 type Chinese 6355 classes, standard JIS Type 1 and Type 2			
Character size	Height can be expanded by 1,2,4,8 or 16 times. Width can be expanded by 1/2,1,2,4,8 or 16 times.			
No. of Char. Display	8×16 dot: 80characters×30 rows 16×16 dot: 40characters×30 rows	8×16 dot: 80characters×25 rows 16×16 dot: 40characters×25 rows	8×16 dot: 40characters×15 rows 16×16 dot: 20characters×15rows	
Character properties	Display properties: normal, reverse, blink, flashing			
Graphics type	Straight line type: line, rectangle, continuous line Curve type: dot, circle, arc, ellipse, ellipse arc, curve Others: fill, bitmap, polygon fill			
Graphics properties	Line type: real line, others: 5 types fill type: 16	Line type: real line, others: 5 types fill type: 2	Line type: real line, others: 5 types fill type: 16	Line type: real line, others: 5 types fill type: 2
	Display properties: normal, reverse, blink, flashing Transparency sets: yes			

7. TOUCH PANEL SPECIFICATIONS

Item	GC-56LC2-1/ GC-55EM2-1	GC-53LC3-1/ GC-53LM3-1
Touch panel	32×24 keys / screen	16×12 keys / screen
Touch key	Matrix type, transparent resistance film	
Lifespan	1,000 thousand times	
Unit size	5.6×5.6mm	
Standard operation force	3.0±1.0N	

8. FUNCTIONAL SPECIFICATIONS

Item	GC-55EM2-1/GC-56LC2-1	GC-53LC3-1/GC-53LM3-1
No. of register screens	Max.1024	
Users memory	FlashROM: 3MB(screen and program)	FlashROM: 1MB(screen and program)
System memory	512K Bytes (Note1)	
Backup memory	256K bytes (only with battery)	
Screen display mode	depends on parts display and control	
No. of register parts	Max. 999 / screen	
Switches operate state	momentary, alternate(ON/OFF), autorepeat	
No. of selected displays	Max. 1024 / part	
Types No. of selected displays	Numeral displays, Character displays, Clocks displays, Graphs displays, Lamps displays, Switches displays, Keys displays, Meters displays, Tubes displays, Bar graph, Trend graph, Pie Graph, Line graph, Pie graph, Alarm displays, etc.	
Clocks/Calendars	Clocks/Calendars function: Yes Retentive function: Yes Calendar precision: ±40sec/ month (Ta=25°C)	
Print screen function	Yes (Note2)	
Buzzer	ON、OFF	
Self-diagnose	System information, Communication port, Display color, Key input	

Note:

- 1) The actual available memory is 400KB.
- 2) Apply to PCPR201,ESC/P.

The Windows printer is incapable of use. You can use the parallel printer or the serial printer.

- 3) Please replacing the battery when the battery indicates low voltage.

In addition, it is essential to installing a fresh battery if the system has not been powered on for a period of more than five years.

9. PROGRAM ENVIRONMENT

Item	Specification
Program mode	According to the software.
Program tools	Software: SCREEN CREATOR 5(above Ver2.22) OS: Windows95/98 Note: Windows NT(above Ver.4.0) available but is unassured. Memory requirements: above 16MB. Hard disk residual capability requirements: above 170MB (cluster: 32KB; FAT16) above 40MB (cluster: 4KB; FAT32) Input equipment: Keyboard, Mouse Others: above 256 Color Display

10. SOFTWARE SPECIFICATIONS

Type	Content	Model	Version
Software system program	Written by us.	CR21-54-R605 later.	GC-56LC2-1/ GC-55EM2-1 XX2.42 later.
			GC-53LC3-1/ GC-53LM3-1 XX2.31 later.
Screen data program	The screen contents written by user.	manage by users	manage by users

11. INSTALLATION PROCEDURES

CAUTION

- Be sure to install the unit in an environment that complies to the general specifications. Avoid using the unit in the following locations.
 - Locations where the ambient temperature and relative humidity exceed the ranges in the general specifications.
 - Locations that are subject to sudden temperature changes that can lead to dew condensation.
 - Locations that have significant amounts of corrosive gases, inflammable gases, solvents and grounding fluids.
 - Locations with excessive amounts of dust, salt and iron dust.
 - Locations that are directly subjected to excessive vibrations and shock.
 - Locations that are subjected to direct sunlight for long periods.
 - Locations where machinery or devices that output strong static are located.

11-1 Installation

The installation can be installed vertically or horizontally.

11-1-1 Panel Installation Hole Dimensions

(1) GC-56LC2-1/ GC-55EM2-1

① Horizontal installation

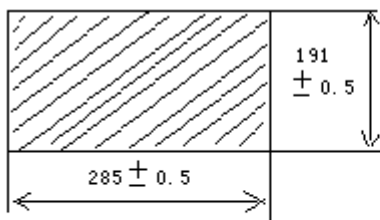

② Vertical installation

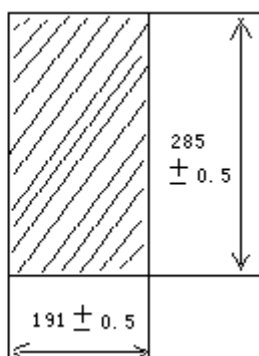

(2) GC-53LC3-1/ GC-53LM3-1

① Horizontal installation

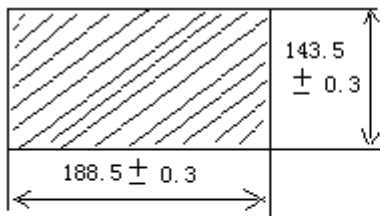

② Vertical installation

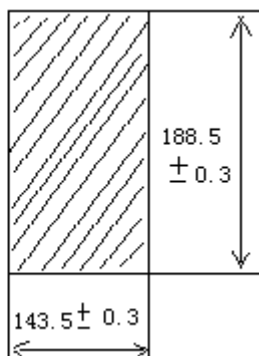

11-1-2 Installing the Packing

The packing is located between the panel and front of the OIP to prevent water and oil from entering the panel interior.

① GC-56LC2-1

Install the packing (V-ring) in the groove around the backside of the front of the OIP (the section that comes into contact with the panel) as shown in the figure below.

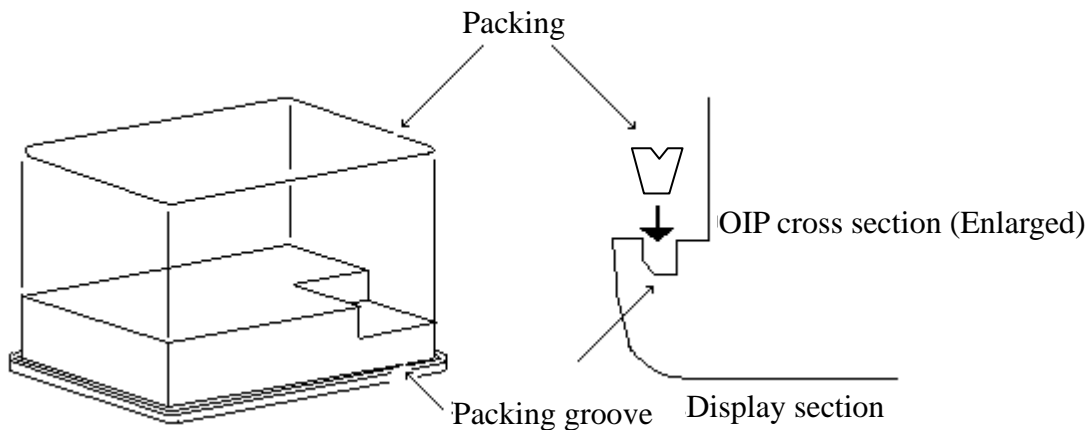

② GC-55EM2-1

Install the packing (V-ring) backside of the front of the OIP (the section that comes into contact with the panel) as shown in the figure below.

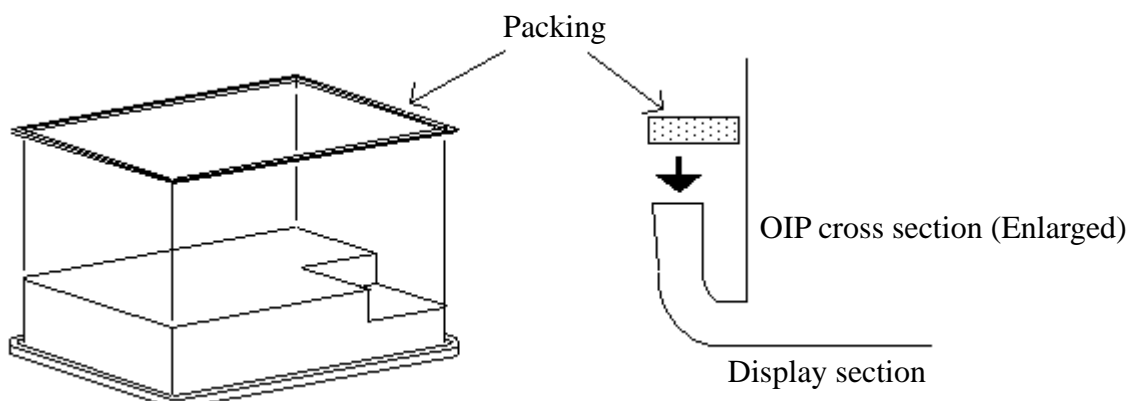

③ GC-53LC3-1/ GC-53LM3-1

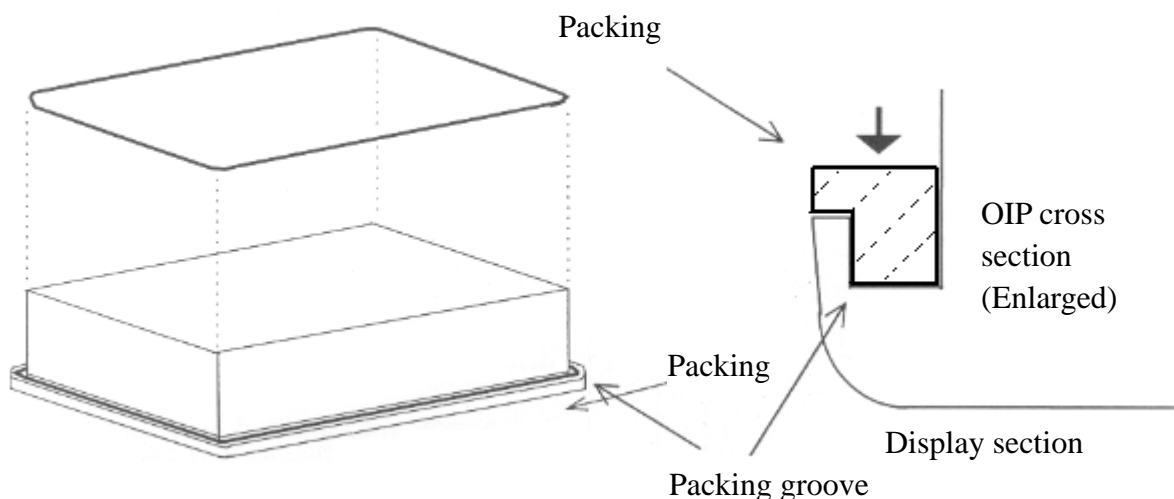

11-1-3 OIP Installation

1. Insert the OIP from the front of the panel, then attach the brackets from the back side of the panel to affix the OIP to the panel.

If your unit is GC-56LC2-1, make sure that the packing is properly placed in the slit on the OIP.

If your unit is GC-55EM2-1, make sure that the edge of packing is not sticking out of the OIP or folded in the OIP.

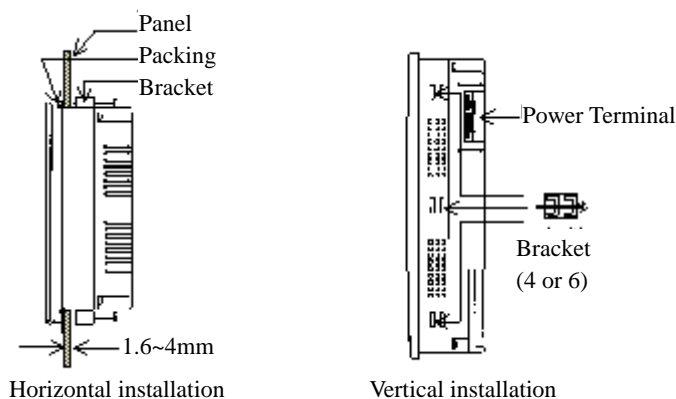

CAUTION

- 1) The panel should be 1.6 to 7 mm thick.
- 2) Use four or six brackets.
- 3) Tighten the bracket screws with a torque from 0.3 to 0.5 Nm. Make sure that the panel and OIP come into even contact. Over tightening the screws can lead to deformation of the OIP case and damage.
- 4) When installing the OIP vertically, make sure that the power supply terminal is located at the top.
- 5) Make sure that the installation surface is flat and smooth. Even if the packing is used, IP65F may not be attainable.
- 6) Because the GC-56LC2-1 uses a color LCD, the optimum viewing angle is limited. Although the optimum viewing angle can be adjusted slightly with the system mode screen settings, there is a limit to these adjustments. Only install the unit after carefully considering the location and angle.

2. The prerequisite to installation is that there will be natural air cooling with vertical installation.

If the unit is installed on a horizontal surface, be sure to use forced air cooling so that the OIP does not accumulate heat.



3. Be sure to allow sufficient ventilation space so that heat from the OIP does not accumulate.

A basic guideline is to keep the OIP at least 100 mm from other devices, parts and surfaces.

4. Install the OIP so that it is not heated by other units.

11-1-4 Installation Bracket Dimensions (Unit: mm)

① GC-56LC2-1/GC-55EM2-1

② GC-53LC3-1/GC-53LM3-1

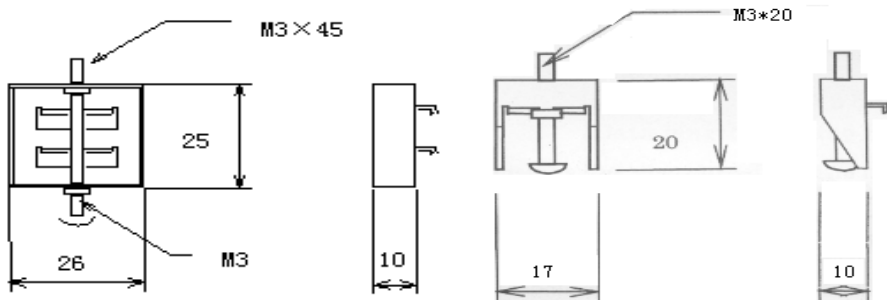

11-2 Power Supply

Follow the instructions below concerning the wiring of the power supply.

1. Use a regulated power transformer when the variance of power voltage exceeds the allowance.

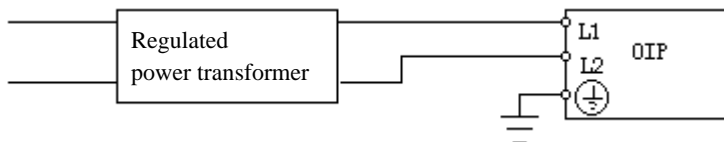

2. Use different power line for the OIP from the one used for power drive devices or output devices.

① GC-56LC2-1/GC-55EM2-1

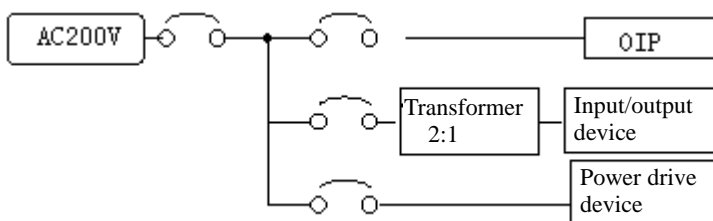
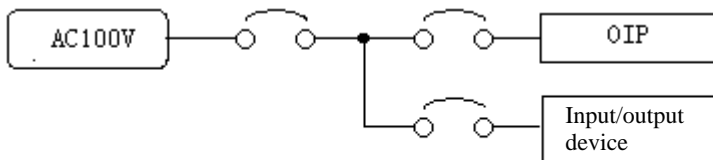

② GC-53LC3-1/ GC-53LM3-1

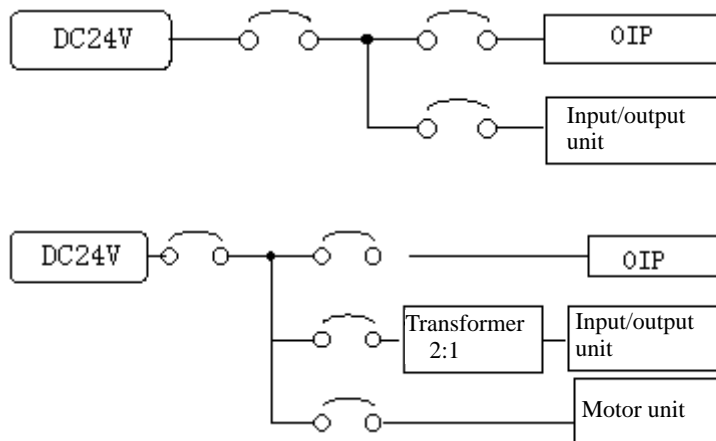

3. Use an isolation transformer if there is a lot of noise on the power line.

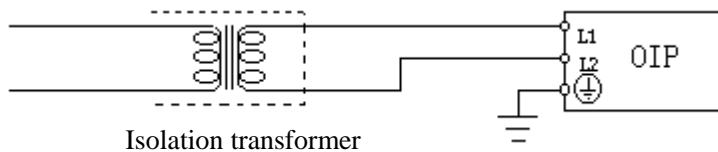

4. Make sure that the power supply line is separated from high voltage lines, motor power lines, and input/output signal by more than 200 mm.
5. Tighten the power supply line screws with a torque under 0.79 Nm.

11-3 Grounding

In order to prevent electrical shock, use a dedicated type 3 grounding line (grounding resistance of under 100 ohms).

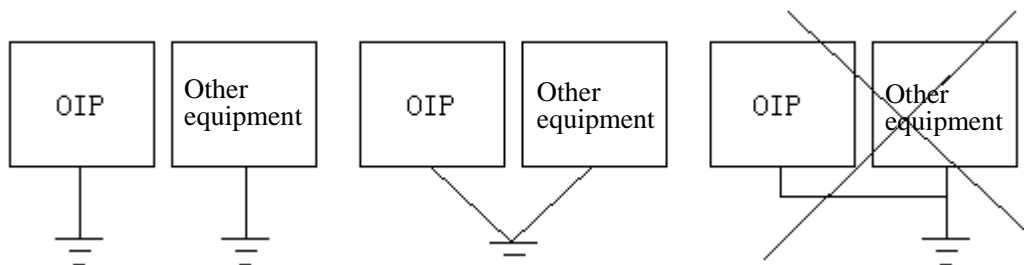

Use a 0.75 to 2 mm² line for grounding.

11-4 Other Connections

Keep all wires for RS-232C, RS-485 communication, RAS output and reset input away from the power supply cable, the high voltage lines, motor power lines and input/output signal lines for more than 200mm.

12. COMMUNICATION PROTOCOL SPECIFICATIONS

The OIP can be set the communication device that connected to the communication port such as a host computer or PLC, etc. The OIP takes the protocol in which the software of the communication driver for connecting PLCs and other external units is to be downloaded together with screen data.

12-1 Command Communication

The OIP can be connected with a general computer or a special controller by use the special serial communication commands. The OIP is a slave station.

12-1-1 Methods of Command Communication

Communication between the OIP and host computer is independent of any one started .The following shows changes in status:

Item		A	B	C	D	E	F	G
Status		send request	receiving right	receiving error	receiving data invalid	ACK received	NAK received	timeout
1	During waiting	command sending →2	ACK sending →1	NAK sending →2	→1	ignore	ignore	—
2	After command sending	sending request logging in	ACK sending →2	NAK sending →2	→2	→1	within the resend times →2 resend times exceeded→1	within the resend times →2 resend times exceeded→1

12-1-2 Packet Structures

The structures of command and response packet are shown below:

- Command (from host computer to OIP)

(253 bytes or less)

Start code	Station No.	Destination name1	T1	Command	Data	T2	Destination name n	T1	Command	Data	End code	SUM	Terminator
------------	-------------	-------------------	----	---------	------	----	-------	--------------------	----	---------	------	----------	-----	------------

- Command (from OIP to host computer)

(253 bytes or less)

Start code	Station No.	Data	End code	SUM	Terminator
------------	-------------	------	----------	-----	------------

- Response command

ACK	Station No.	Terminator
-----	-------------	------------

NAK	Station No.	Terminator
-----	-------------	------------

Name	Description	Required or not	Data length	Range	Default
Start code	Starting code of the packet	○/×	1 byte	01 – 7FH	02H
Station No.	Station number of the OIP	○/×	2 bytes	00 – FF (ASCII code)	Not used
Destination name	Screen name and part name	○	—	—	—
T1	Terminator of the destination name	○	1 byte	01 – 7FH	01H
Command	Command	○	1 byte	39H (fixed)	—
Data	Outgoing numeric/character string data to the destination	○	—	—	—
T2	Terminator of the outgoing data to the destination	○	1 byte	01 – 7FH	04H
End code	Ending code of the outgoing data	○	1 byte	01 – 7FH	03H

12-2-2 Functions

The memory link communication provides two type functions ,and are listed below. Commands are expressed as ASCII code.

	Type 1	Type 2
Data that can be sent from the host to the OIP	<ul style="list-style-type: none"> • Data is written into table (in word or in bit) • Data is read from table (in word or in bit) 	<ul style="list-style-type: none"> • Data is written into table (in word or in bit) • Data is read from table (in word or in bit)
Data that can be sent from the OIP to the host	<ul style="list-style-type: none"> • Only one byte of data which has been written into table #0 can be sent in binary form to the host • Response to a normal or an abnormal write command is not made to the host 	<ul style="list-style-type: none"> • Data that has been written into table #0 value can be sent using a command. • Data that has been written into table #1 and #2 range can be sent using a command. • Response to a normal or an abnormal command is sent to the host.

12-2-3 Command Package Structures

Command package structures are showed below:

E S C	Sta. No. (can be omitted)	Command	Parameter 1	Parameter N	C R
-------	---------------------------	---------	-------------	-------	-------------	-----

12-3 Non Procedure Communication

“The Non procedure communication” is a communication method that the communication protocol must be described with K-Basic. Using this communication method, the OIP can be connected with modems that having its own protocol. The communication program described with K-Basic and the screen data is to be downloaded to the OIP at the same time.

Using this communication method, the OIP can be a master station or a slave station.

12-4 Direct Access Communication

“The direct access” is a communication method that the OIP can be connected to a PLC to perform data read/write operations directly on the devices of the PLC. The OIP is a master station and the PLC is a slave station. No ladder programs are therefore required for communication. Otherwise, the OIP have flexibility protocol to correspond to many different kinds of PLCs, the protocol can be downloaded together with screen data when select a corresponding PLC.

12-5 Others Communication method

The OIP can be used to communicate with bar code readers, and other devices that having their own protocols, etc. The protocol can be downloaded together with screen data.

13. INTERFACE SPECIFICATONS

13-1 RS232C (CH1,CH2)

1. Transmission specifications

No.	Item	Description
1	Communications method	Full duplex
2	Synchronization	Start-stop synchronization
3	Transmission distance	15m
4	Connection type	1:1
5	Transmission rate	1200, 2400, 4800, 9600, 19200 and 38400 bps (set with the communications parameters)
6	Data format	Start bit: 1 bit Stop bit: 1 and 2 bits Data length: 7 and 8 bits Parity: EVEN, odd and none (Set with the communications parameters.)

2. Connector pin numbers and signals

• CH1, CH2 (Option)

Pin number	Signal	Direction	Description
1	FG		Protective grounding
2	SD	Output	Transmitted data
3	RD	Input	Received data
4	RS	Output	Transmission request signal
5	CS	Input	Reception enabled signal
6	Not used		
7	SG		Signal GND
8	Not used		
9	+5V		5V power supply (for optional equipment)

※ RS-CS with CH2 is internally connected inside the OIP.

3. Connector pin layout (OIP unit)

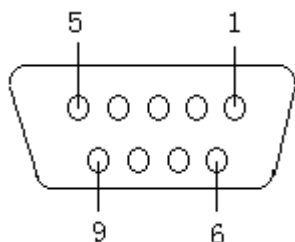

D-SUB connector (female)

• Usable connectors

Plug: XM2A-901 (OMRON) or equivalent

Shell: XM2S-0911 (OMRON) or equivalent

13-2 RS422 (CH3)

1. Transmission specifications

No.	Item	Description	
1	Communications method	Full duplex, five lines	Half duplex, three lines
2	Synchronization	Start-stop synchronization	
3	Transmission distance	500 m (total length)	
4	Connection type	1: N ($N \leq 32$) N: PLC units	M: N ($M+N \leq 32$) M: OIP units N: PLC units
5	Transmission rate	1200, 2400, 4800, 9600, 19200 and 38400 bps (set with the communications parameters)	
6	Data format	Start bit: 1 bit Stop bit: 1 and 2 bits Data length: 7 and 8 bits Parity: Even, odd and none (Set with the communications parameters.)	

2. Connector pin numbers and signals

GC-55EM2-1/GC-56LC2-1:

Pin number	Signal	Direction	Description
1	RD-	Input	Received data (-)
2	(CTS)	Input	Reception enabled signal
3	SG1	—	Signal GND
4	SD-	Output	Transmitted data (-)
5	SD-	Output	Transmitted data (-)
6	SG2	—	Signal GND
7	(RTS)	Output	Transmission request signal
8	RD-	Input	Received data (-)
9	RD+	Input	Received data (+)
10	FG1	—	Protective grounding
11	SD+	Output	Transmitted data (+)
12	(+5V)	—	5V power supply (for optional equipment)
13	SD+	Output	Transmitted data (+)
14	FG2	—	Protective grounding
15	RD+	Input	Received data (+)

Note) CTS,RTS and +5V are only for expansion, cannot be used for RS485.

GC-53LC3-1/GC-53LM3-1:

Pin number	Signal	Direction	Description
1	SD+	Output	Transmitted (+)
2	SD-	Output	Transmitted (-)
3	RD+	Input	Received data (+)
4	RD-	Input	Received data (-)
5	SG	—	Signal GND
6	FG	—	Protective grounding

3. Connector pin layout (OIP unit)

GC-56LC2-1/GC-55EM2-1: The connector is a Dsub-15pin connector.

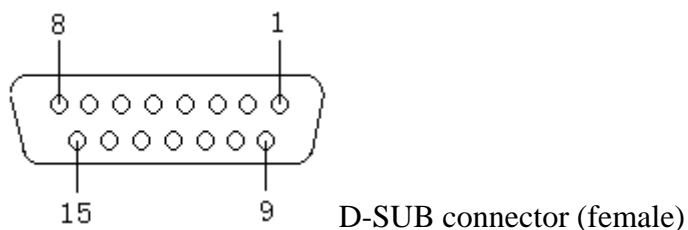

Usable connectors:

Plug: XM2A-1501 (OMRON) or equivalent

Shell: XM2S-1511 (OMRON) or equivalent

GC-53LC3-1/GC-LM3-1: The connector is a terminal board layout.

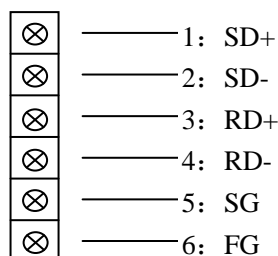

4. Internal circuit

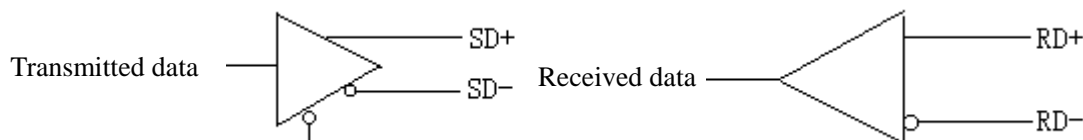

Note: A terminal resistor is not built in, so add one to the terminal board if necessary.

13-3 Printer (only GC-56LC2-1/GC-55EM2-1)

1. Connector pin numbers and signals

Pin Number	Signal	Pin Number	Signal
1	STB	8	D6
2	D0	9	D7
3	D1	10	-
4	D2	11	BUSY
5	D3	12	-
6	D4	13	-
7	D5	14	GND

- Printer cable
PC-8894 (NEC) or equivalent

2. Connector pin layout (OIP unit)

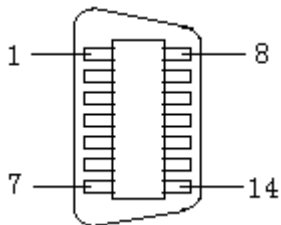

- Usable connectors
57K-3014S (DDK) or equivalent

13-4 RAS/Reset

1. Connector pin numbers and signals

Pin Number	Signal	Description
1	RAS+	System error output (+)
2	-	
3	-	
4	-	
5	RST+	External reset input (+)
6	RAS-	System error output (-)
7	-	
8	-	
9	RST-	External reset input (-)

2. RAS

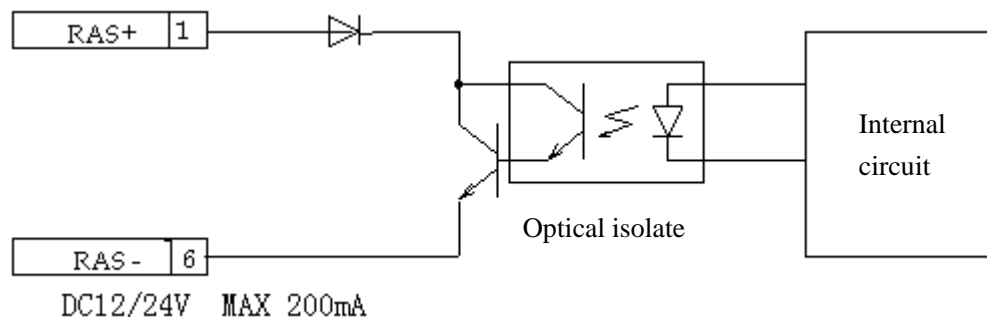

3. Reset signals (RST)

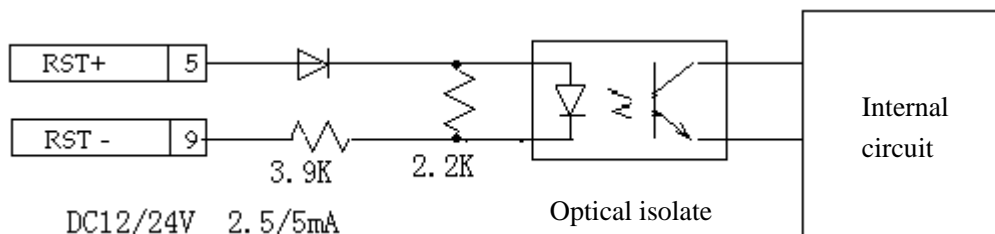

4. Connector pin layout (OIP)

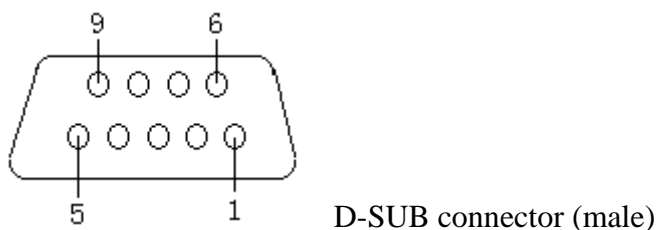

• Usable connectors

Plug: XM2D-0901 (OMRON) or equivalent

Shell: XM2S-0911 (OMRON) or equivalent

13-5 Notice for 5V power supply (Option)

The total current available from RS232C (CH1), RS232C (CH2) and RS485 (CH3) port is maximum 3000mA. Do not exceed this.

14. OPERATION PREPARATIONS

14-1 System Language Setting

Select a language for OIP system screen or Error message either Japanese or English can be selected. (Can not be changed once it has set in this screen.)

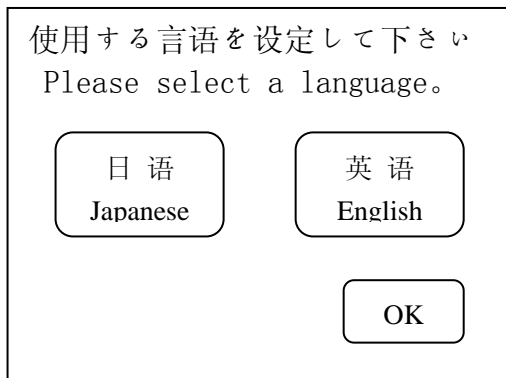

In case it is necessary to change, changeable during 14-3-9 System Language Setting.

14-2 Screen Download

Use the optional dedicated download cable (GC-S1C1-DEE) for downloading.

For details on the internal connections of the download cable, refer to the “Download” section of the “Screen Creator 5 User’s Manual: Operation.”

When using the OIP for the first time the user screen data has not been download, so that when the power is turned on the system mode screen menu will be displayed. Execute downloading with the following procedure.

- 1) Connect the download cable to the RS-232C connector (CH1). The communications parameters will be set automatically.
- 2) Select download from the system mode menu. The download screen will be displayed, and the unit will wait for communications.
- 3) Start the screen creation software “Screen Creator 5,” and execute downloading. Refer to the “Basic Operation” section of the “Screen creator 5 User’s Manual: Operation.”
- 4) To cancel downloading, press the cancel switch on the screen.
When cancelled after downloading is started, all the contents in memory will be cleared.
- 5) After downloading is completed, the screen will display the normal end screen.
- 6) After the confirm switch is pressed, the unit will return to the menu. Select user mode and start operation.

When screen data has already been download the unit will not go to the system mode when power is turned on. Therefore, if downloading is required to make change in the screen data, then follow the procedures described in section 14-3 to go to the system mode screen.

14-3 System Settings

There are two methods for switching to the system mode screen.

- If the OIP is installed horizontally hold down the switch on the upper left of the touch panel or if it is installed vertically hold down the switch on the lower left, then turn on the power.
- When in the user mode in which the user screen is displayed, simultaneously press the switches on the upper left and lower right of the touch panel, regardless of the way the OIP is installed.

If a screen has not been download, then turning on the power will display the system mode screen menu.

Transition when power is turned on

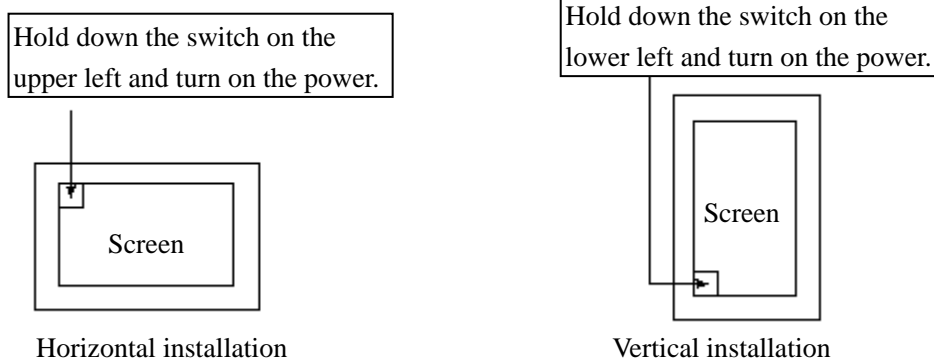

Transition from the user mode

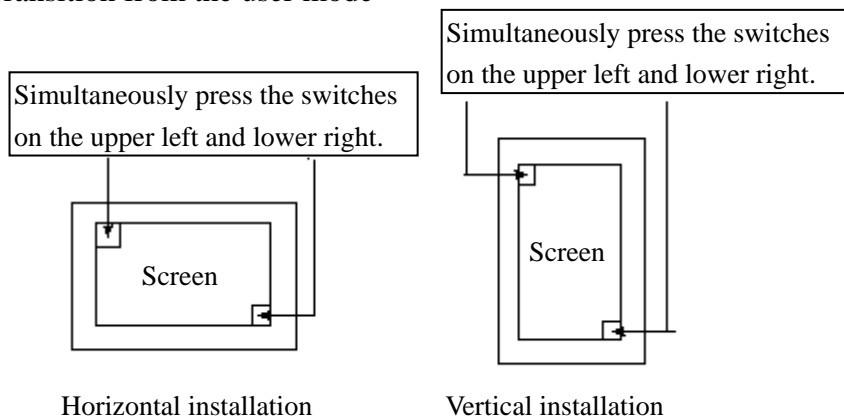

When transformed the screen from the user mode, the screen of the OIP enter the system mode.

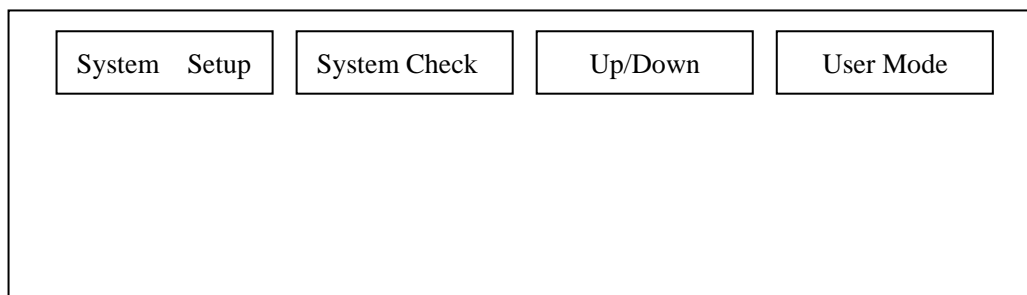

In each screen the "RET" key stands for enter and the "ESC" key stands for cancel.

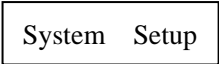
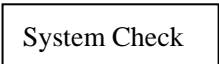
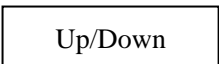
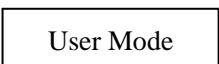
- Press  key, enter the screen of the system parameters set.
- Press  key, enter the screen of the system check.
- Press  key, enter the screen of the user data upload/download.
- Press  key, enter the screen of the user.

14-3-1 Communication Port Setting

Set the communications type and communications parameters for the various communications ports.

- 1) Select “System Setup” from the menu of the system mode.

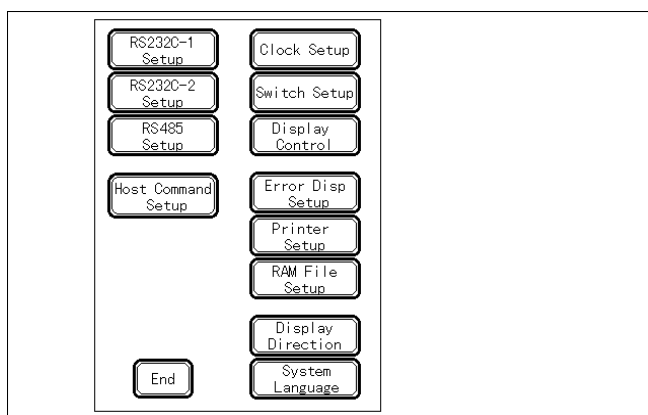

- 2) Select the communication port from the system setting menu. The setting screen of the corresponding port will be displayed. Set the various parameters.(Communications type, communications rate, parity, stop bit and data length.)

Note: If the settings for the connected unit have not been made in “Screen Creator 5”, the communications type cannot be set.

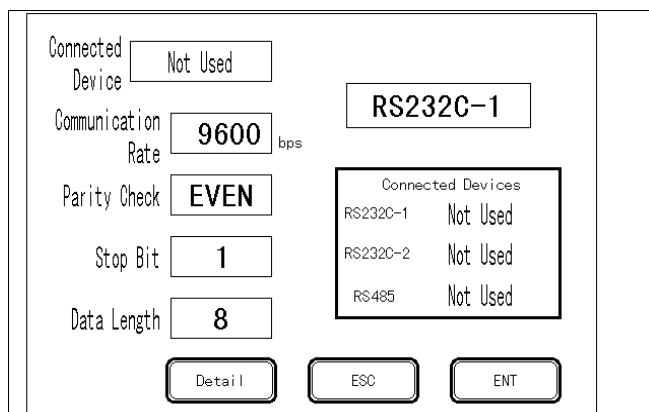

- 3) Touch the communication “Connected Device” frame. The device selection menu appears. Then, touch the device to connect.

Note: This selection is ignored unless a communication protocol is down-loaded together with screen data beforehand.

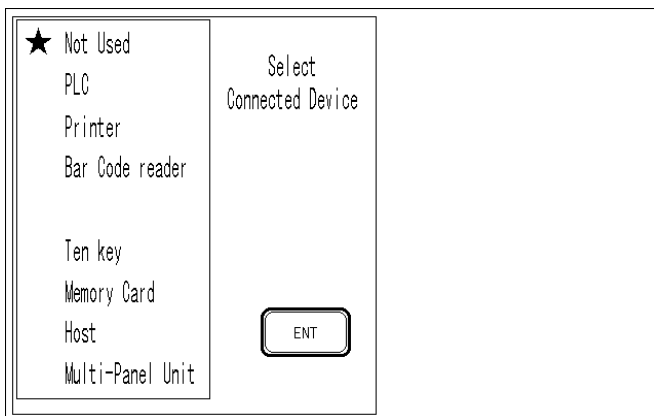

- 4) Click “ENT” to return to the communication parameters setting menu, and you can make the detailed settings. Select “Detail” on the screen, set the number of times to retry, timeout time, station number, and Xon/Xoff control.

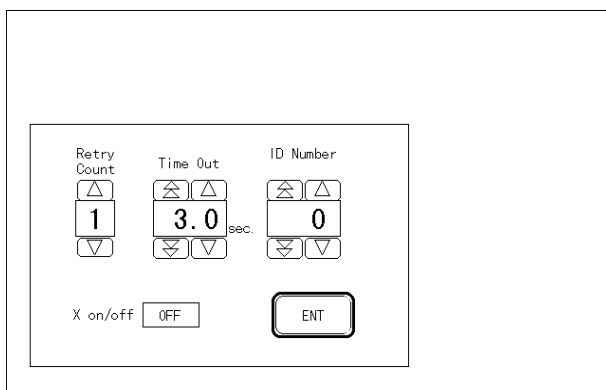

Click “ESC” to return to the communication parameters setting menu, and the setting is ignored.

Click “ENT” to return to the communication parameters setting menu, and the setting is available.

14-3-2 Host Communications Settings

When a special serial communications protocol is to be used (host command method or memory link method), set the communications data format. Only the station number category is valid for the memory link method.

Select “Host Command Setup” from the system mode menu. The setting screen of the host communication parameters setting screen will be displayed.

14-3-3 Calendar and Clock Setting

Select “Clock Setup” from the menu of the system mode.

- Choice can be switch are pressed each (Year. Month. day. hour. min).
- Sec set to 00 when setting finished.

14-3-4 Click Setting

Select whether there is a click sound when a switch is pressed and set the total number of multiple switches which was almost simultaneous are pressed .

Select “Switch setup” from the menu of the system mode.

14-3-5 Display Control

Select “ Display Control” from the menu of the system mode.

① Display Off time setting

This function turns off the display when there is no switch input for a set time. Up to 60 minutes can be set at one minutes intervals. If the display is to be left on at all times, set this to 0.

② Brightness setting

The brightness of the display can be set to one of eight settings.

③ View angle adjustment (only for GC-56LC2-1)

After installing the unit on the panel, adjust the angle where you have optimized contrast when viewing the display from the normal position. When the unit has user configure screen, call up the color pallet used for the screen by choosing user configured screen number.

14-3-6 Error Display Setting

Select “ Error Disp. Setup” from the menu of the system mode.

Select the method for displaying error messages (bottom of the screen or in a window) when errors caused by user applications are generated.

Screen bottom: Messages and four digit error codes will be displayed at the bottom of the screen.

Windows display: Error messages will be displayed in the error display unit that was assigned when creating the screen.

These settings are only valid for error codes 4000 to 4499 and those in the 5000 to 5999.

14-3-7 Printer Setup

Select “Printer Setup” from the system setting menu.

When a printer is to be used, set “Output Port”, “Protocol”, “Printer Mode”, “Time-out”.

During hardcopy the display, the function of “switches action”, “data update display” and “screen switches” can not be executed.

14-3-8 RAM File Setup

Set the size of the system RAM as the RAM file. The usable range is limited by the system RAM size and the number of the screens. When the RAM file is not to be used, the size must be set to 0.

14-3-9 Display Direction

Select "Display Direction" from the menu of the system mode.

This setting determines whether the OIP is to be used horizontally or vertically. User data screen, System and Error display change by configuration.

14-3-10 System Language Setting

Selectable among Japanese and English (2 modes).

Note: The setting contents is stored in flash memory when all of them change to the user mode except the display direction.

After the setting was completed, press the user mode switch in the screen menu.

14-4 Before Operation

Check the following items before starting operation for the first time.

- Has screen data been downloaded correctly?
- Have the various system settings been made correctly?
- Have the connectors been connected correctly?
- Is power being supplied correctly?
- Are the connections correct?

15. Battery

The OIP contains a coin type lithium battery for clock and memory backup.

Note!

Replace the battery immediately when it indicates low battery voltage.
Replace the battery if it is kept in power-off for more than 5 years, regardless of what the battery voltage indication is.

15-1 Battery Type

Caution:

Use coin type lithium battery. (Toshiba CR2025)

15-2 How To Replace The Battery

Caution: Power up and wait for more than 5 min. before replacing the battery.

This allows built-in capacitor to be charged enough for backing up the memory.

- 1) Power off and disconnect the power wires on the terminal block.
- 2) Remove the battery cover located on the back-panel of the unit.
- 3) Remove the old battery from holder and place the new battery.

Caution:

Make sure that the battery is installed in right polarity.

- ① Complete replacing the battery within 3 minutes.
- ② Make sure that the battery does not falls into the OIP.

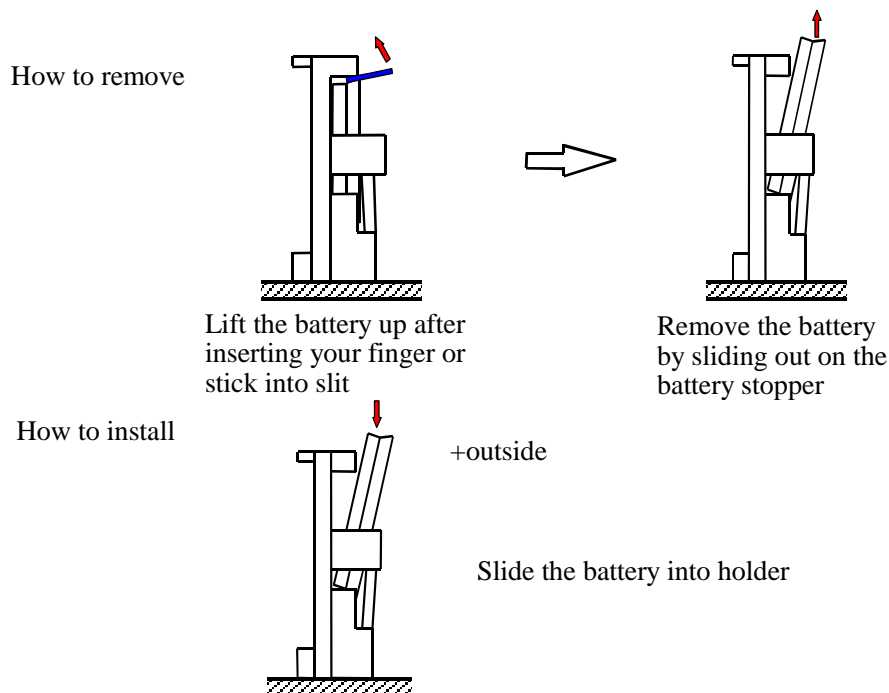

- 4) Install the battery cover and tighten the screws.

16. BACKLIGHT (EXCEPT GC-55EM2-1)

- Use of back-light under the following conditions may cause the brightness and life time of back-light to be greatly reduced.
 - at low ambient temperatures (below 5 degrees C).
 - frequent ON and OFF of the back-light
- The expected life time of the battery is about 20,000 hours or more at room temperature, but it is reduced into 1/20 if the unit is used in low temperature (below 5 degree C).

17. MAINTENANCE AND INSPECTION

- The touch panel is made of glass, so when wiping it off be sure not to apply too much pressure. Applying too much pressure may break the glass.
- Do not wipe the touch panel with thinner, organic solvents, ammonia or strong acids.
- In order to clean the touch panel and case, soak a soft cloth or cotton in diluted neutral detergent or industrial alcohol, and wipe them.
- When using protective sheets, remove the old sheet, then immediately apply a new one. Protective sheets are available as options.

18. PERIODIC INSPECTION

Conduct a periodic inspection of the OIP once or twice a year.

Also conduct the inspection below after moving the OIP, modifying it, or changing the connections.

	Item	Description	Criteria	Action
1	Power supply voltage	Measured at the power supply input terminal	Within the range of the general specifications.	Change the supplied power.
2	Ambient environment	Ambient temperature	Within the range of the general specifications.	When used in a cabinet, the temperature in the cabinet should be considered the ambient temperature.
		Ambient humidity		
		Atmosphere		
3	Installation	Are the installation screws loose?	Not loose	Tighten the screws.
		Are the connectors loose?	Not loose	Tighten the connector screws.
		Are the power supply input terminal screws loose?	Not loose	Tighten the screws.
		Are there any problems with wiring?	Broken lines or taught lines	Modify the wiring.
4	Build-in Battery	Is the battery replaced?	power OFF time: 5 years	Replace the battery

光洋电子(无锡)有限公司

Koyo ELECTRONICS (WUXI) CO., LTD.

地址: 江苏省无锡市滨湖区建筑西路 599 号 1 栋 21 层

邮编: 214072

电话: 0510-85167888

传真: 0510-85161393

<http://www.koyoele.com.cn>

KEW-M9013A

2015 年 8 月